

## Operating Instructions

# Elados<sup>®</sup> EMP KKS E60 and Elados<sup>®</sup> EMP KKS E60<sup>PLUS</sup>

Softwareversion 4.0 or 4.1



Fig. 0.2

**EMP KKS E60<sup>PLUS</sup>** (with Dongle-Box)



Fig. 0.1

**EMP KKS E60**

## Table of contents

<b>1</b>	<b>General</b> .....	<b>5</b>
1.1	Warranty coverage .....	5
1.2	Contact address / Manufacturer .....	5
<b>2</b>	<b>Safety</b> .....	<b>6</b>
2.1	Safety Notes .....	6
2.2	Emphases .....	6
2.3	Numberings .....	6
2.4	Special safety Notes for maintenance and repair work .....	6
<b>3</b>	<b>Delivery scope</b> .....	<b>7</b>
3.1	Upgrade accessories for the EMP KKS E60 <sup>PLUS</sup> .....	7
<b>4</b>	<b>Functional description</b> .....	<b>8</b>
4.1	Mechanical functions .....	8
4.2	Electronic functions .....	8
4.3	Additional electronic functions on the EMP KKS E60 <sup>PLUS</sup> .....	8
<b>5</b>	<b>Setup</b> .....	<b>9</b>
5.1	EMP KKS E60 .....	9
5.2	EMP KKS E60 <sup>PLUS</sup> .....	9
5.3	Indicators / Controls / Jacks .....	10
5.3.1	EMP KKS E60 and EMP KKS E60 <sup>PLUS</sup> versions .....	10
5.3.2	“Dongle box” ports .....	10
<b>6</b>	<b>Mounting</b> .....	<b>11</b>
6.1	Mounting diagram .....	11
<b>7</b>	<b>Device installation</b> .....	<b>12</b>
7.1	Hydraulic installation .....	12
7.1.1	Installation examples .....	12
7.1.2	Connecting the suction line and return line .....	14
7.1.3	Connection of pressure line .....	15
7.2	Electrical installation .....	15
7.2.1	Inputs and outputs .....	15
7.2.2	Connector assignments of Slot I (3-terminal) input for low-level advance warning and empty report .....	16
7.2.2.1	Installing the suction pipe with low-level advance warning and empty report .....	16
7.2.3	Connector assignment of slot II (5-terminal) input for pulse signal, standard signal, metering lock, batch and metering monitoring .....	17
7.2.3.1	Installing the pulse control (water meter) .....	17
7.2.3.2	Installing the standard signal control .....	18
7.2.3.3	Installing the control via the metering lock .....	18
7.2.3.4	Installing the batch function .....	19
7.2.3.5	Installing the metering monitoring .....	19
7.2.4	Connector assignments of slot III (4-terminal) output for alarm and stroke signal .....	20
7.2.4.1	Installing the alarm or fault report output at 24 V .....	20
7.2.4.2	Installing the stroke signal output at 24 V / DC .....	21
7.2.4.3	Installing the alarm output at 115/230 V / AC .....	21
7.2.4.4	Hardware migration for alarm contact .....	22
7.2.5	Connector assignments of slot IV, mains power supply .....	22
<b>8</b>	<b>Upgrading the EMP KKS E60 to the EMP KKS E60<sup>PLUS</sup></b> .....	<b>23</b>
8.1	Fitting the dongle box .....	23
8.2	Connector assignments of the slots .....	24
8.2.1	Connector assignments of slot V (5-terminal), input for oval gear meter .....	24
8.2.1.1	Installing the oval gear meter .....	24
8.2.2	Connector assignments of Slot VII (5-terminal) input for batch pulse and metering lock .....	25
8.2.2.1	Installing the batch pulse .....	25
8.2.2.2	Installing the metering lock (optional connector VII or VIII) .....	26
8.2.3	Connector assignments of Slot VIII (5-terminal) input for pulse, standard signal input and metering lock .....	27
8.2.3.1	Installing the pulse control (water meter) .....	27
8.2.3.2	Installing the standard signal (mA) .....	28
8.2.3.3	Installing the metering lock .....	28
<b>9</b>	<b>Startup</b> .....	<b>29</b>
9.1	Switching on the pump .....	29
9.2	Switching off the pump .....	29
9.3	Key functions .....	29
9.4	Initial startup / Delivery status .....	29
9.4.1	Software version display .....	30
9.4.2	Display at operating display .....	30
9.4.3	Configuration .....	30

<b>10</b>	<b>Menu description .....</b>	<b>31</b>
10.1	Main menu .....	31
10.1.1	Overview .....	31
10.2	Operation mode .....	32
10.2.1	Selecting .....	32
10.2.2	Operation mode / internal .....	32
10.2.2.1	Selecting .....	32
10.2.2.2	Display in the operating display/ Setting .....	33
10.2.3	Operation mode / pulse .....	33
10.2.3.1	Selecting .....	34
10.2.3.2	Display in the operating display/ Setting .....	34
10.2.4	Operation mode / current (external standard signal) .....	35
10.2.4.1	Selecting .....	35
10.2.4.2	Display in the operating display .....	36
10.3	Configuration .....	37
10.3.1	Overview .....	37
10.3.2	“Scrolling the display“ .....	37
10.3.3	Configuration / Language .....	37
10.3.3.1	Selecting .....	37
10.3.4	Configuration / Unit .....	38
10.3.4.1	Selecting .....	38
10.3.5	Configuration / Code .....	38
10.3.5.1	Selecting .....	38
10.3.5.2	Setting .....	39
10.3.6	Configuration / Autostart .....	39
10.3.6.1	Selecting .....	39
10.3.7	Configuration / Metering lock .....	39
10.3.7.1	Selecting .....	40
10.3.8	Configuration / Low-level contact .....	40
10.3.8.1	Selecting .....	40
10.3.9	Configuration / Alarm output .....	40
10.3.9.1	Selecting .....	41
10.3.9.2	Conversion from alarm relay mode to contact mode. ....	41
10.3.10	Configuration / pulse memory .....	41
10.3.10.1	Selecting .....	41
10.3.10.2	Display in the operating display with an active pulse memory .....	42
10.3.11	Configuration / Oval gear meter (only E60 <sup>PLUS</sup> & OGM or OGM <sup>PLUS</sup> ) .....	42
10.3.11.1	Selecting .....	42
10.3.12	Configuration / Metering controller“ (only E60 <sup>PLUS</sup> & OGM <sup>PLUS</sup> ) .....	43
10.3.12.1	Selecting .....	43
10.3.12.2	Display in the operating display with an active metering controller .....	44
10.3.13	Configuration / Metering monitoring .....	44
10.3.13.1	Selecting .....	44
10.3.13.2	Metering monitoring / Stop pump .....	45
10.3.13.3	Metering monitoring / Strokes .....	45
10.3.13.4	Metering monitoring / Deviation (only at E60 <sup>PLUS</sup> & OGM or OGM <sup>PLUS</sup> ) .....	46
10.3.13.5	Metering monitoring / Input (only at E60 <u>WITHOUT Dongle box</u> ) .....	46
10.3.13.6	Oval gear meter pulse display (only E60 <sup>PLUS</sup> ) .....	47
10.3.14	Configuration / MicroFlow <sup>PLUS</sup> .....	47
10.3.14.1	Selecting .....	47
10.3.14.2	MicroFlow <sup>PLUS</sup> / Stop pump .....	48
10.3.14.3	MicroFlow <sup>PLUS</sup> / Strokes .....	48
10.3.14.4	MicroFlow <sup>PLUS</sup> / Deviation .....	48
10.3.14.5	MicroFlow <sup>PLUS</sup> / Metering break .....	49
10.3.14.6	MicroFlow <sup>PLUS</sup> / Metering delay .....	49
10.3.14.7	MicroFlow <sup>PLUS</sup> / Calibration .....	50
10.3.15	Configuration / Batch .....	50
10.3.15.1	Selecting .....	50
10.3.15.2	Batch / Quantity .....	50
10.3.15.3	Batch / Input (only at E60 <u>WITHOUT Dongle box</u> ) .....	51
10.3.15.4	Display in the operating display .....	52
10.3.16	Configuration Degas <sup>PLUS</sup> .....	52
10.3.16.1	Selecting .....	52
10.3.16.2	Degas / Degas strokes .....	53
10.3.16.3	Degas / Degas break .....	53
10.4	Calibration .....	54
10.4.1	Overview .....	54

10.4.2	Calibration pump.....	54
10.4.2.1	Preparation .....	54
10.4.2.2	Calibration / Start .....	55
10.4.3	Calibration pump with oval gear meter (OGM <sup>PLUS</sup> ) .....	55
10.4.3.1	Preparation .....	55
10.4.3.2	Calibration / Start .....	56
10.4.4	Calibration / Manual.....	57
10.4.4.1	Calibration data table.....	57
10.5	Operating data .....	57
10.5.1	Overview.....	58
10.5.2	Operating data / Operating hours .....	58
10.5.2.1	Selecting / Displaying / Deleting .....	58
10.5.3	Operating data / Liter .....	58
10.5.3.1	Selecting / Displaying / Deleting .....	59
10.5.4	Operating data / Amount of pulses .....	59
10.5.4.1	Selecting / Displaying / Deleting .....	59
<b>11</b>	<b>Maintenance .....</b>	<b>60</b>
11.1	Replacing the suction / return valve.....	60
11.1.1	Inserting the metering valves in the correct positions .....	61
11.2	Replacing the diaphragm and pump head .....	61
11.3	Replacement of ceramics cylinder unit with piston .....	62
11.4	Description of the stroke scale.....	63
<b>12</b>	<b>Operating faults .....</b>	<b>64</b>
12.1	Metering warning messages (display) .....	64
12.2	Alarm messages (display) .....	64
12.2.1	Trouble shooting.....	65
<b>13</b>	<b>Wearing parts and spare parts (standard version).....</b>	<b>66</b>
<b>14</b>	<b>Technical Specifications .....</b>	<b>67</b>
14.1	Pump key.....	67
14.1.1	Pump key definition E60 .....	69
14.2	Dimensions .....	70
14.3	Technical specifications "Overview tables" .....	71
14.3.1	General data .....	71
14.3.2	General data - Standard pumps .....	71
14.3.3	In-/ and output circuit .....	72
14.3.3.1	Connector I .....	72
14.3.3.2	Connector II .....	72
14.3.3.3	Connector III .....	72
14.4	Materials .....	73
14.5	Connector assignments.....	73
14.5.1	Connector assignments: Connector I (3-terminal) .....	73
14.5.2	Connector assignments: Connector II (5-terminal) .....	73
14.5.3	Connector assignments: Connector III (4-terminal) .....	73
14.6	Metering rates.....	74
14.7	Delivery capacity in relation to the back pressure.....	74
14.7.1	Delivery capacity in relation to the stroke length.....	75
<b>15</b>	<b>Declaration of Conformity .....</b>	<b>76</b>

## 1 General

This Technical Manual contains all of the instructions for installing, starting up, maintaining and repairing membrane metering pumps of the **ELADOS® EMP KKS E60** and **ELADOS® EMP KKS E60<sup>PLUS</sup>** classes with software version 4.0 or 4.1.

**IMPORTANT**

**Please note your pump's software version when using these operating instructions**  
(see chapter [9.4.1](#)).

**NOTE**

The German sections of this manual constitute the **ORIGINAL OPERATING MANUAL** and take legal precedence.  
All other languages are translations of the **ORIGINAL OPERATING MANUAL**.

**The safety Notes and emphases must be observed at all times!**

### 1.1 Warranty coverage

Operational safety, reliability and performance of this model are only guaranteed by the manufacturer if the following conditions are met:

- Mounting, connections, adjustment, service and repair are performed by authorized and trained personnel.
- The membrane metering pump must be used according to the specifications in the operating instructions contained in the delivery scope.
- Only original spare parts must be used for repairs.
- The warranty claim is invalidated if the pump housing is opened.

**In addition, the general warranty and service conditions of the company [ECOLAB Engineering GmbH](#) are applicable.**

### 1.2 Contact address / Manufacturer

#### **ECOLAB Engineering GmbH**

Raiffeisenstraße 7  
**D-83313 Siegsdorf, Germany**

Telephone (+49) 86 62 / 61 0

Fax (+49) 86 62 / 61 2 35

eMail: [engineering-mailbox@ecolab.com](mailto:engineering-mailbox@ecolab.com)





## 2 Safety

### 2.1 Safety Notes

- Connection and repair work on the membrane metering pump must only be performed by authorized technical personnel.
- The power supply plug must always be disconnected before starting any work on electrical components.
- Appropriate protective clothing must be worn for any maintenance and repair work.
- The safety regulations for handling chemicals must always be observed.

### 2.2 Emphases



The emphases indicated in this maintenance guide have the following meanings:

	<b>CAUTION</b>	Used when improper compliance or non-compliance with the operating instructions, work instructions, prescribed working routines, et cetera, may result in injury or accidents.
	<b>WARNING</b>	Used when improper compliance or non-compliance with the operating instructions, work instructions, prescribed working routines, et cetera, may result in damage to the equipment.
	<b>IMPORTANT</b>	Used when particular attention is required in operating the equipment.
	<b>NOTE</b>	Used to draw attention to a noteworthy detail.

### 2.3 Numberings

- ✘ Numberings marked with this sign (✘) describe an activity which must only be performed by the installer / user.

### 2.4 Special safety Notes for maintenance and repair work

	<b>CAUTION</b>	<p>Prior to repair and maintenance work and metering of dangerous media, always rinse the metering head, relieve the pressure pipe and wear protective clothing (protective goggles, gloves and apron).</p> <p>Electronics repairs must only be performed by trained electricians, following the safety regulations of the professional association VB G 4 &amp; ZH 1/11!</p> <p>When opening covers or removing parts, components carrying live voltages may be exposed.</p> <p>Connection points may also be under live voltages.</p>
	<b>IMPORTANT</b>	Only original spare parts must be used for repairs.

### 3 Delivery scope

The delivery scope consists of:

Fig. 3.1



Fig. 3.2



Fig. 3.3



Fig. 3.4



- metering pump, version **EMP KKS E60** including mains power supply cable (2 m) with shock-proof plug and dummy plug for inputs and outputs
- 5-terminal connector plug for pulsed or standard signal input
- Adapters (for tube 4/6, 6/8, 6/12 (ID/AD) mm)
- Assembly sketch for tube connections (accessory)
- Connector assignment plan (accessory)
- Operating Instructions (item no. 417101774)

#### 3.1 Upgrade accessories for the **EMP KKS E60<sup>PLUS</sup>**

Fig. 3.5



- Dongle box (item no. 248606)

## 4 Functional description

### 4.1 Mechanical functions

The ELADOS® EMP KKS series of metering pumps take the form of electrically (motor) driven diaphragm displacement pumps.

The membranes are for the pre-delivery, the piston is for the metering. Because of the permanent overpuls refeeding this metering pump works self venting.

The metering pumps are suitable for use with clean, non-abrasive metering media with a viscosity of up to 200 mPas (measuring manner: Brookfield).

The metering pump is operated by a non-blocking synchronous motor and a connecting rod-eccenter gear.

Fig. 4.1

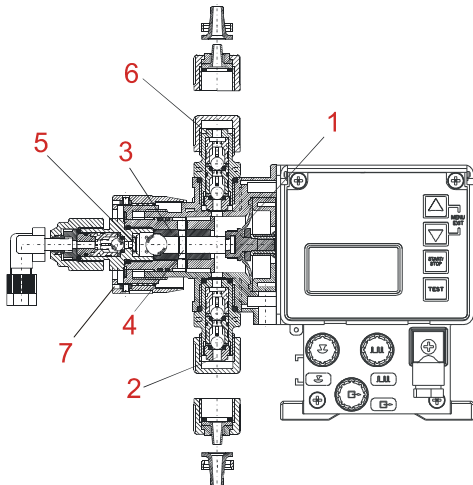

When the diaphragms (pos. 1) moves towards the gear, the valve (pos. 2) suck up the metering product. Simultaneously, vacuum grow out of the compression chamber of the metering piston cylinder unit (pos. 3). When the inspection hole (pos. 4) has been released, the pre-delivered metering product flows into this chamber. During the pressure motion metering happens over the valve (pos. 5); the surplus product get returned into the container by the return valve (pos. 6). The stroke adjustment (pos. 7) regulates the volume delivered during the operation from 0 - 100 %. This changes the immersion depth of the cylinder. The pre-delivered amount keeps constant.



#### WARNING

To protect the metering device, the use of a suction pipe with an empty reporting device and dirt arrestor (available from our range of accessories) is highly recommended!  
The empty reporting device switches off the pump if it falls below a certain level (in the container).

### 4.2 Electronic functions

The pump may be used in three different operation modes:

INTERNAL Manual metering function (factory setting)  
EXTERNAL pulse control  
EXTERNAL standard signal control (mA)

The pump is operated using four keys (Fig. 5.5, Pos 2, 3, 4 and 5) (see "chapter 9.3 Key functions").

The operating indicator is shown on a graphical display (Fig. 5.5, Pos 6).

### 4.3 Additional electronic functions on the EMP KKS E60<sup>PLUS</sup>

- Oval gear meter connection
- Oval gear meter evaluation
- Metering regulation with a oval gear meter, type OGM<sup>PLUS</sup>
- Automatic calibration is possible thanks to the oval gear meter, type OGM<sup>PLUS</sup>
- Splitting of the metering lock/pulse/metering monitoring/oval gear meter inputs into multiple connections to simplify the external connections.



## 5 Setup

### 5.1 EMP KKS E60

Fig. 5.1

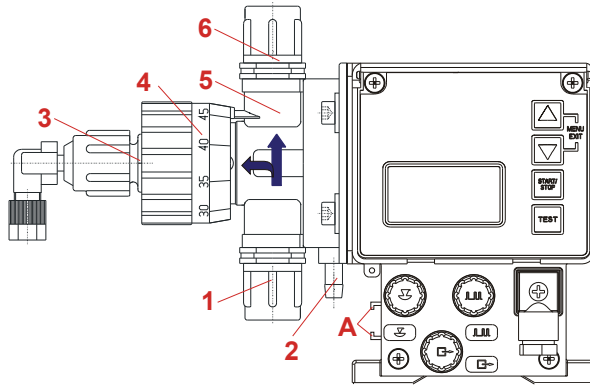
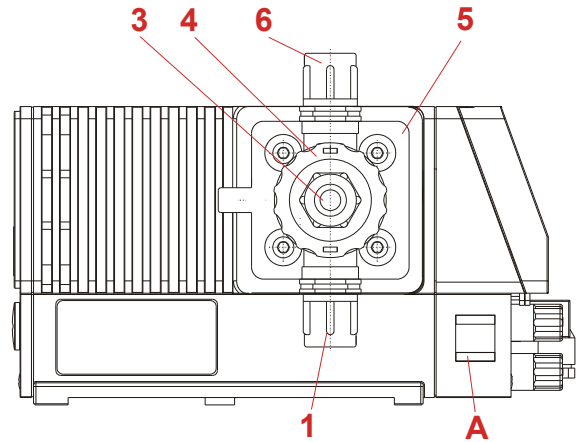

Fig. 5.2



### 5.2 EMP KKS E60<sup>PLUS</sup>

Fig. 5.3

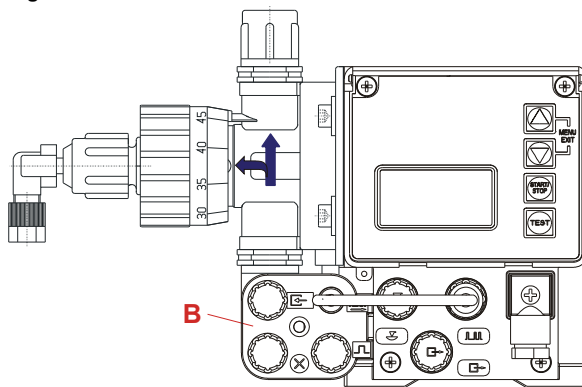
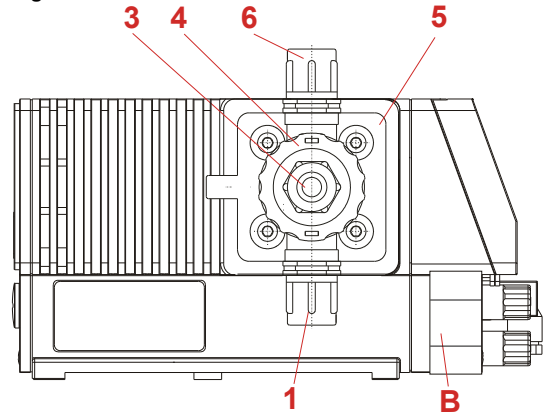



Fig. 5.4



Pos.	Description
1	Suction valve (connection on the suction side)
2	Diaphragm breakage sequence
3	Venting connection (refeeding into the container)
4	Stroke length adjustment
5	Pump head
6	Pressure valve (connection on the pressure side)
A	Rail for connecting the dongle box
B	Dongle box
	Flow direction of the metering medium

### 5.3 Indicators / Controls / Jacks

#### 5.3.1 EMP KKS E60 and EMP KKS E60<sup>PLUS</sup> versions

Fig. 5.5

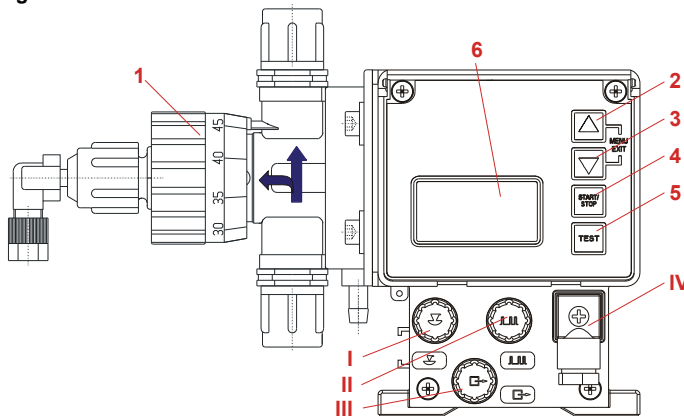

Pos.	Description
1	Control knob for setting the stroke length
2	Menu/Exit, up arrow key
3	Menu/Exit, down arrow key
4	Start/Stop key (Enter function)
5	Test key
6	Graphical display

Pos.	Description
I	input for low-level advance warning and empty report (see <a href="#">7.2.2</a> & <a href="#">14.5</a> )
II	input for pulse- / standard signal and metering lock (see <a href="#">7.2.3</a> & <a href="#">14.5.2</a> )
III	and empty report, fault report and stroke signal (see <a href="#">7.2.4</a> & <a href="#">14.5.3</a> )
IV	mains power supply (see <a href="#">7.2.5</a> )

#### 5.3.2 “Dongle box” ports

Fig. 5.6

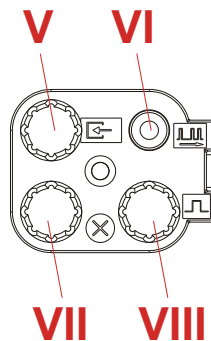

Pos.	Description
V	input for oval gear meter
VI	connection for pulse input to EMP pump (input II)
VII	input for batch pulse and metering lock
VIII	input for pulse, standard signal input and metering lock

## 6 Mounting

**! WARNING** The installation must only be performed by authorized personnel and the general guidelines and local installation regulations must be observed!

- The metering pump should be fitted in an easy-to-access, frost-free location. The ambient temperature must not exceed +40° C.
- The mounting position of the device must be horizontal.

### 6.1 Mounting diagram

Fig.. 6.1

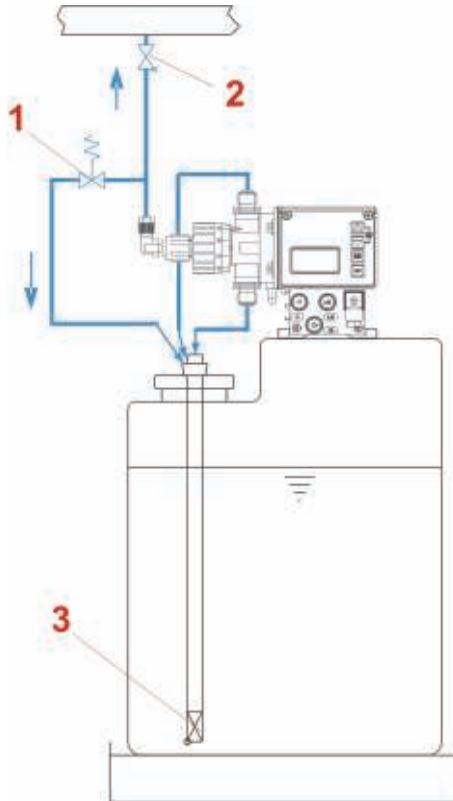

Pos.	Description
1	pressure relief valve
2	metering valve / pressure control valve
3	suction pipe / bottom admission valve



#### NOTE

The metering valve, pressure control valve and pressure relief valve can be replaced by a multifunction valve (MFV) from our product range, which combines all of these functionalities.

## 7 Device installation

### 7.1 Hydraulic installation

#### 7.1.1 Installation examples

 **NOTE** The installation examples and applications provided here are of a functional nature. They give an overview of installation types which are correct or to be avoided for the correct functioning of the pump.

 **WARNING** Specific measures and protection devices for the metering of dangerous or aggressive chemicals are not provided here.  
When using such chemicals, always observe the legal regulations and the relevant product datasheet.

A) The arrangement of the metering pump should preferably be made on and/or over the metering container.

 **NOTE** For media with a tendency towards sedimentation, the bottom admission valve or foot valve of the suction line / suction lance must be fitted above the anticipated layer of sludge.

B) Between the back-pressure in the injection point and the pressure at the metering pump a positive difference of pressure must prevail of at least 1 bar. If this is not the case, a pressure control valve must be built into the metering line.

In addition it recommends to install itself for the avoidance of inadmissibly high pressures in the metering line an appropriate safety overflow valve. The by-pass pipe of this valve should be led back pressure-free into the container.

 **WARNING** The overflow line never be fed back into the suction line of the metering pump.

C) In the injection point in principle a spring-tensioned injector or metering valve should be inserted (also during a metering into pressure-free systems).

For metering in pipelines with underpressure, a pressure control valve must be built into the metering pipe.

 **NOTE** A pressure control valve or a metering valve is not an absolutely hermetically sealing shutoff device.

To prevent the running out of the metering medium when the pump is stopped, we also recommend the fitting of a solenoid valve which is approved for use with the pump.

Fig. 7.1

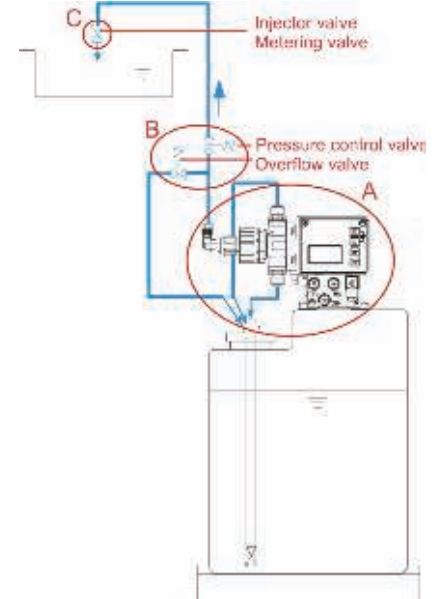
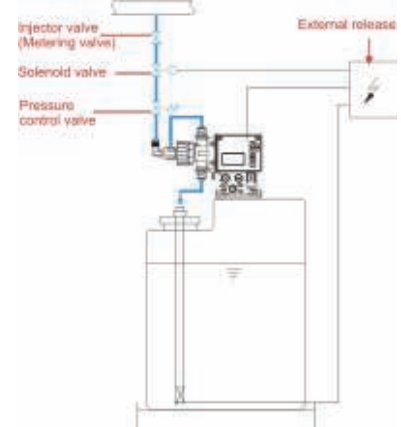

Fig. 7.2



The suction pipes must be kept as short as possible. Long and twisted suction pipes may lead to air buildup in the system.

The max. suction height is 2 m and the max. flow velocity is 0.3 m/s!  
(see also [chapter 14.3](#) "Technical Specifications")

Always lay the suction pipe so that it ascends to the suction valve of the metering pump.

Installation of a metering monitoring system:

A metering monitoring system – oval gear meter or flow indicator - has to be installed in the metering pipeline between the pressure relieve valve and the pressure control resp. metering valve.

Fig. 7.3

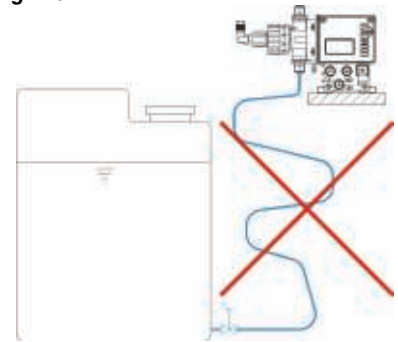

Fig. 7.4

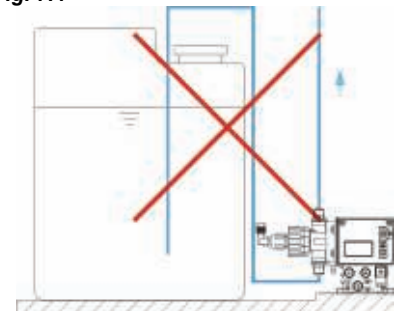
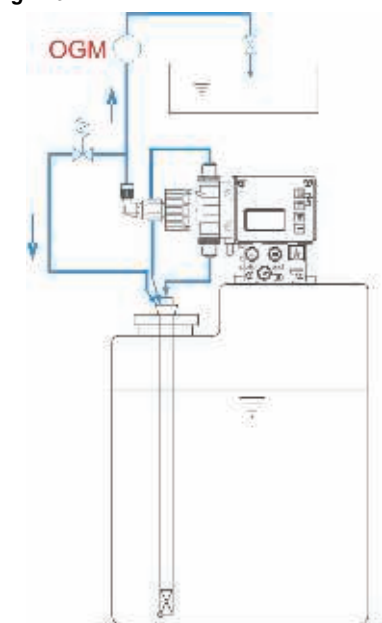
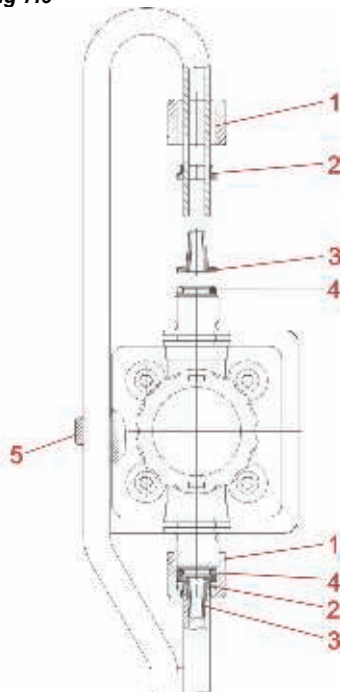

Fig. 7.5



## 7.1.2 Connecting the suction line and return line

Fig 7.6



Pos.	Description
1	Union nut
2	Clamping piece
3	Connection piece
4	O-ring
5	Fixing hole



### CAUTION

When connecting the suction and pressure pipes, ensure that the O-rings (Pos. 19) are fixed to the connectors so as to achieve the required seal.



### NOTE

The use of an appropriate suction pipe from our product range is recommended.



### CAUTION

When using other hose lines adjust the curved radius correspondingly. The return hose must not be bent. During the installation make sure that no the return line is not on tension.

- ✘ Separate double-hose according to the diagram, cut it straightly and remove the connecting bridge.
- ✘ Push the union nut (pos. 1) and clamping piece (pos. 2) over the suction hose piece
- ✘ Attach the connection piece (pos. 3) until stop motion.
- ✘ Put the O-ring (pos. 4) in valve groove and screw down the union nut by hand.
- ✘ Pull the return hose piece through the fixing hole (pos. 5) and attach it as suction hose piece.
- ✘ Set suction lance into the container.

### 7.1.3 Connection of pressure line

Fig. 7.7

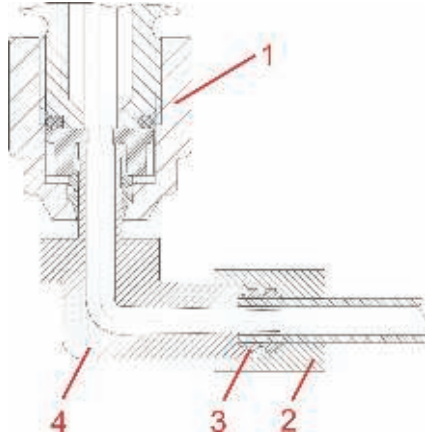

- ✘ Cut off the metering hose or pipe straightly.
- ✘ Push over the union nut (pos. 2) and crimping ring (pos. 3).
- ✘ Attach the hose or the pipe onto the connection piece (pos. 4) until the stop motion and screw it up by hand.
- ✘ Adjust angled position by loosening and screwing down the nut again (pos. 1).

**CAUTION** Observe max. permissible operation pressure of metering hose/pipe!

**NOTE** After 24 hours of operation, the metering head screws should be screwed down diagonally to 3 - 4 Nm.

**CAUTION** The metering pump head may contain residual water from the production tests.

## 7.2 Electrical installation

### 7.2.1 Inputs and outputs

Fig. 7.8

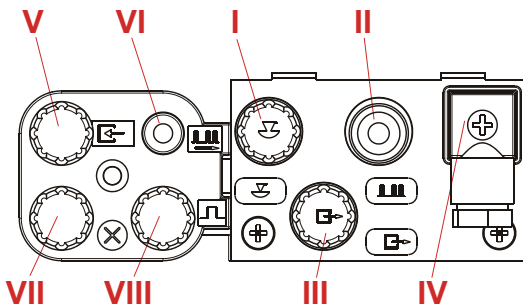

The inputs and outputs are equipped with protective caps in the as-delivered condition. These caps must be removed when necessary. (Pos. I-VIII)

**NOTE** Since the protective caps or connector plugs are coded, the respective images must be observed (I-III). Do not use force when inserting them.

**WARNING** To protect the electronics against contact with chemicals or humidity, never operate the metering pump without protective caps or connector cables, since the connectors can become oxidized.  
Mixing up the protective caps may result in malfunctions of the pump and/or damage to the connectors!

## 7.2.2 Connector assignments of Slot I (3-terminal) input for low-level advance warning and empty report

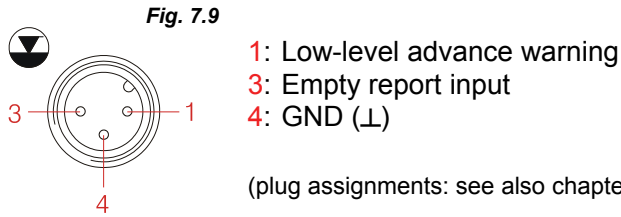

(plug assignments: see also chapter [14.5.1](#) "Technical Specifications")

### 7.2.2.1 Installing the suction pipe with low-level advance warning and empty report

✂ When using a suction pipe, remove the dummy connector and mount the suction pipe connector.



#### NOTE

Slot I must always be assigned, either through the mounted strapping plug (protective cap with corresponding symbol; see chapter [7.2.1](#), Fig. 7.8, Pos. I) or through connection to the empty report device.

The setup of low level contact is invertible. (see chapter [10.3.8](#) "Configuration Low level contact")

Fig. 7.10

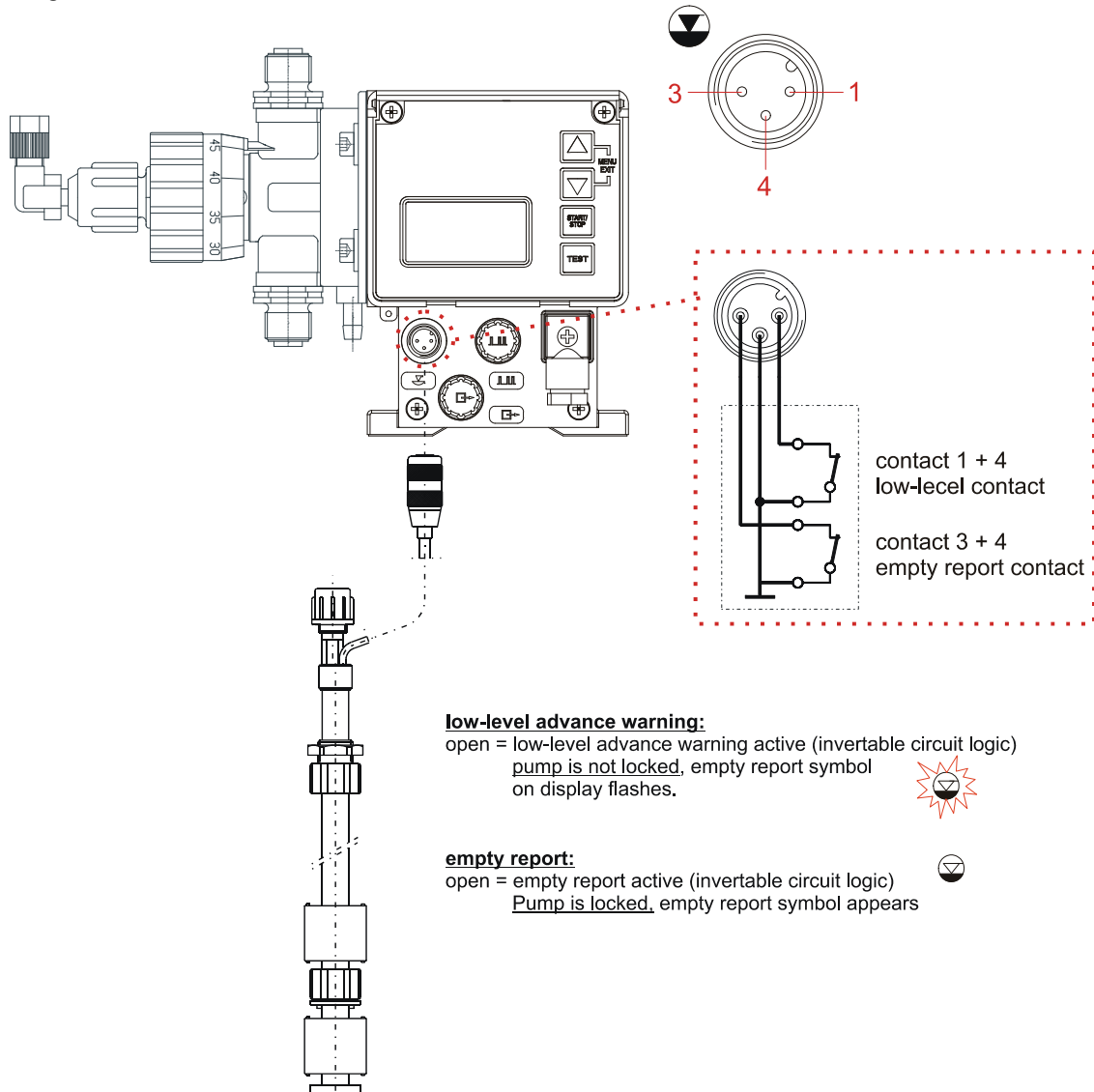



### 7.2.3 Connector assignment of slot II (5-terminal) input for pulse signal, standard signal, metering lock, batch and metering monitoring

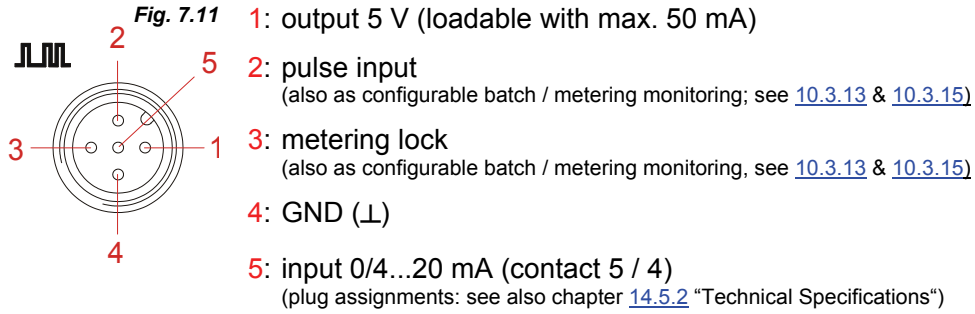

✘ Remove the protective cap

✘ Mount the connector plug according to the connector assignment.



**WARNING** Only use a connector plug from our product range! (included in the delivery scope)

#### 7.2.3.1 Installing the pulse control (water meter)

**Fig. 7.12**

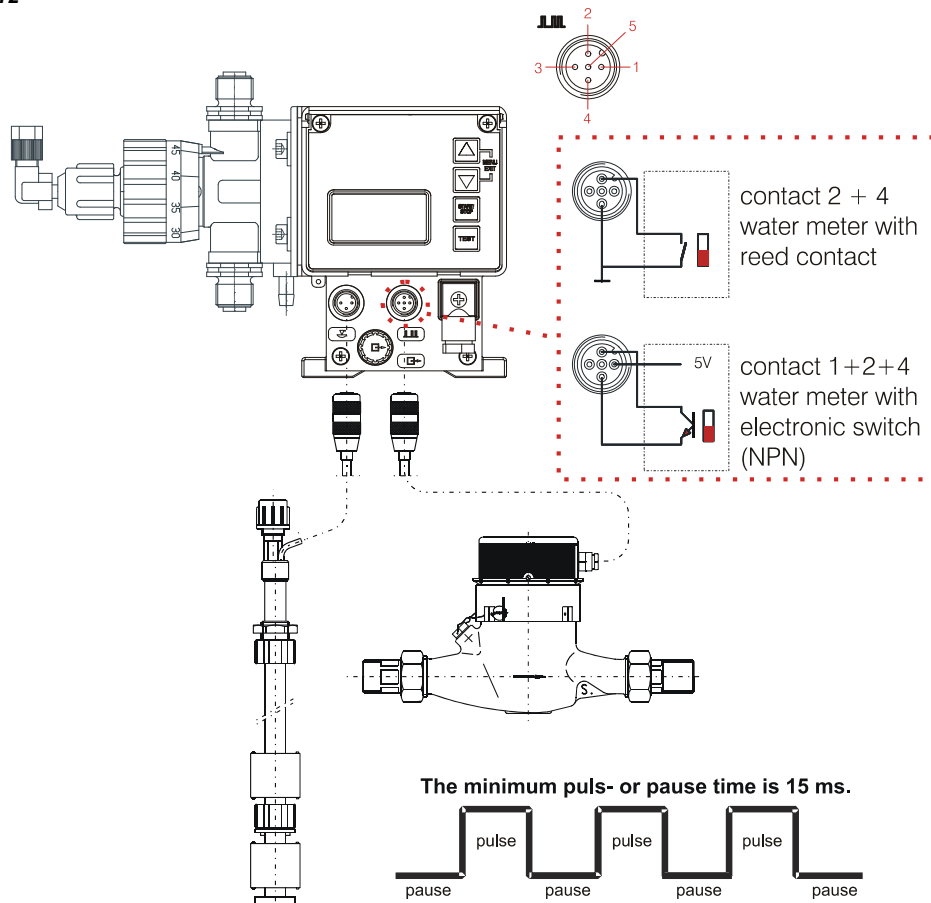

### 7.2.3.2 Installing the standard signal control

Fig. 7.13

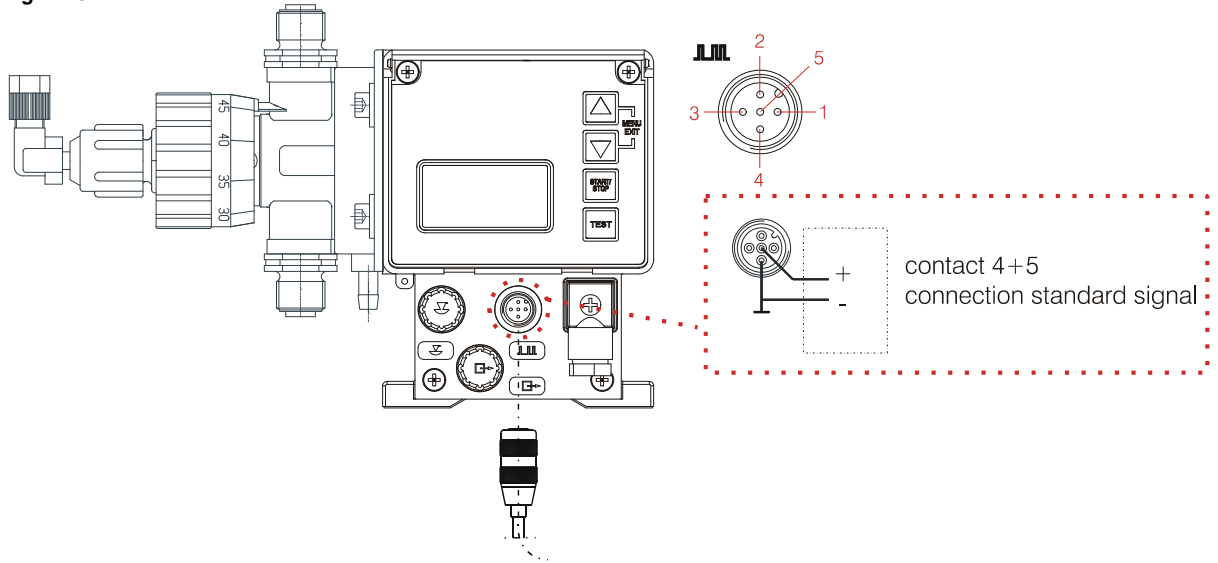

### 7.2.3.3 Installing the control via the metering lock



**NOTE**

The metering lock funktion must be activated in menu first.  
(see chapter: [10.3.7](#) Configuring the metering lock).

The metering lock is available in all operation modes.

Fig. 7.14

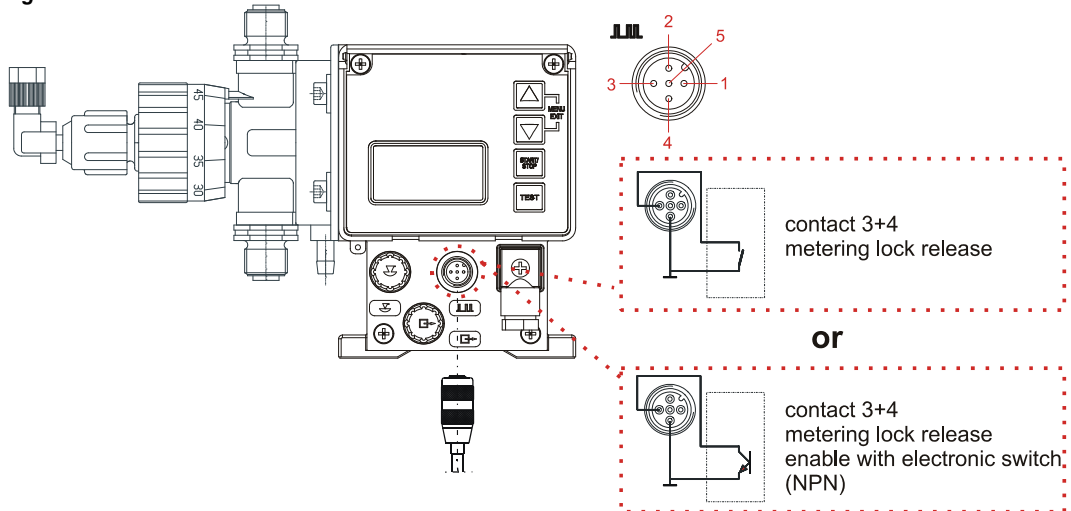

### 7.2.3.4 Installing the batch function

 **HINWEIS** The batch funktion must be activated in menu first. (see chapter [10.3.15](#) batch configuration)  
 According to the requirements, the input of the batch pulse (contact 2+4 or contact 3+4) must be configured. (see chapter [10.3.15](#).)

Fig. 7.15



### 7.2.3.5 Installing the metering monitoring

Fig. 7.16

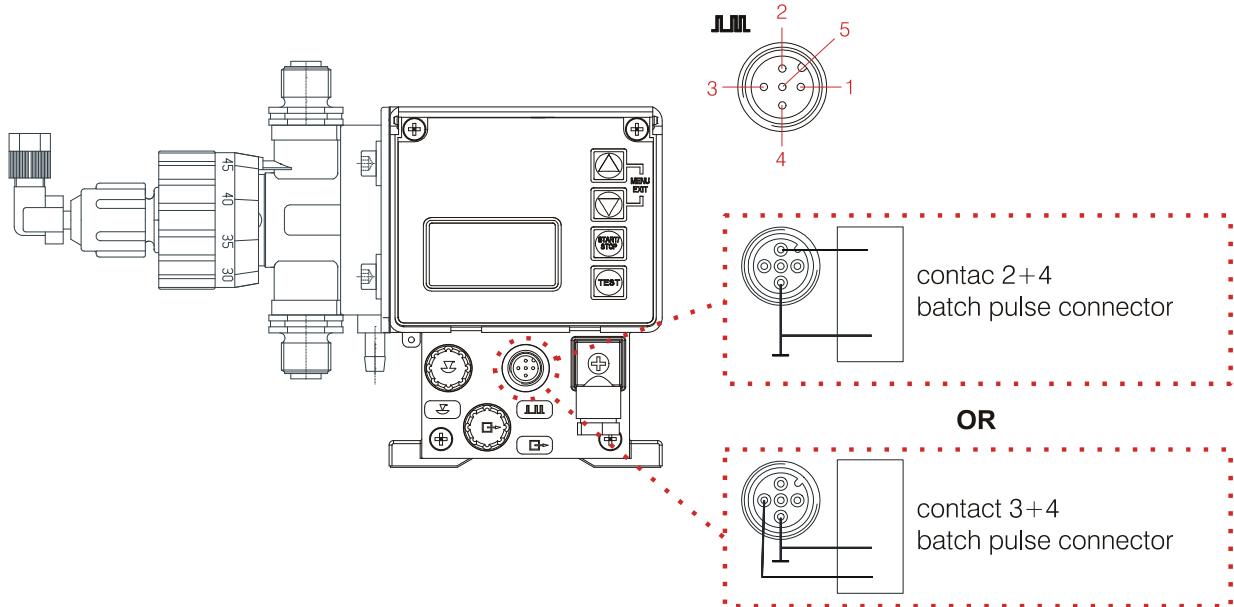
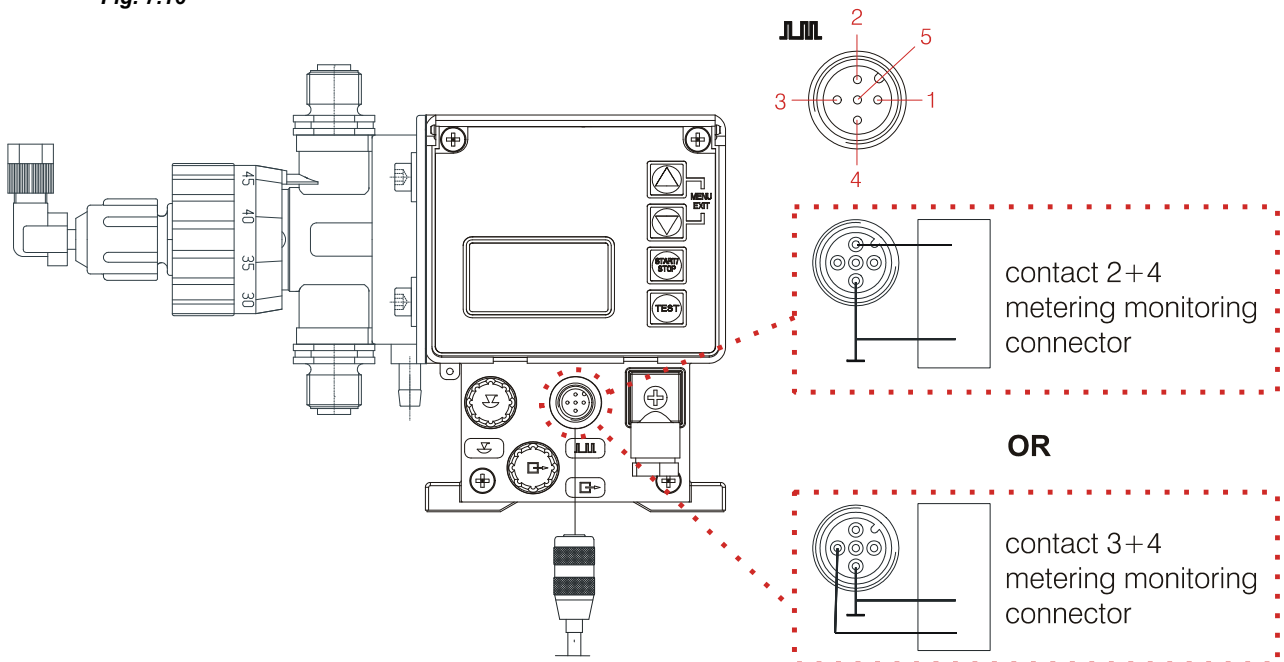

 **NOTE** The input of the metering monitoring can be configured according to requirements. (see chapter [10.3.13](#))

## 7.2.4 Connector assignments of slot III (4-terminal) output for alarm and stroke signal

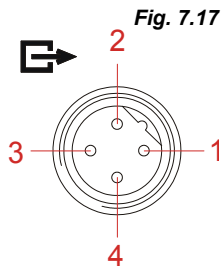

1: Low-level advance warning, empty report and fault

2: Low-level advance warning, empty report and fault

3: Stroke signal (+)

4: Stroke signal (-)

(plug assignments: see also chapter [14.5.3](#) "Technical Specifications")

✘ Remove the protective cap

✘ Mount the connector plug according to the connector assignment.



**WARNING** Only use a connector plug from our product range! (included in the delivery scope)

### 7.2.4.1 Installing the alarm or fault report output at 24 V

Fig. 7.18

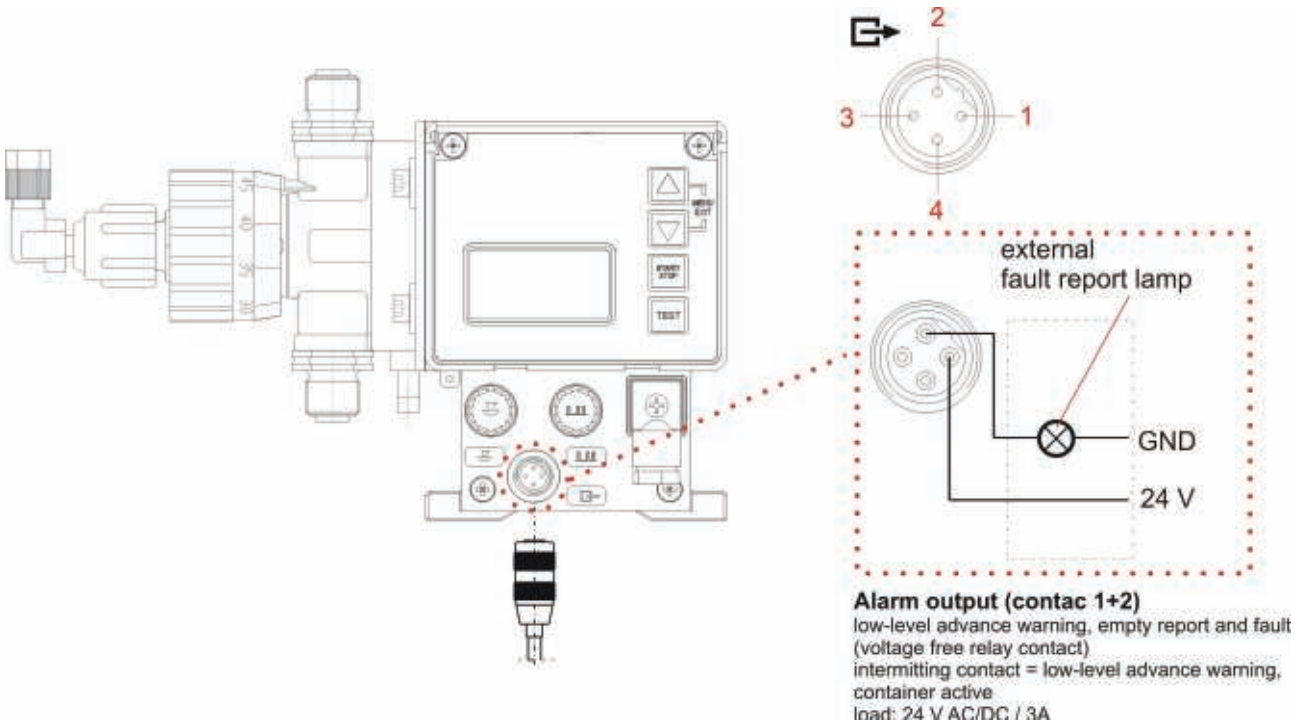

Standard configuration:

closed = empty report container active or error message

Other configuration see chapter [7.2.4.4](#) (Hardware) and chapter [10.3.9](#) (software /menu)

### 7.2.4.2 Installing the stroke signal output at 24 V / DC

Fig. 7.19

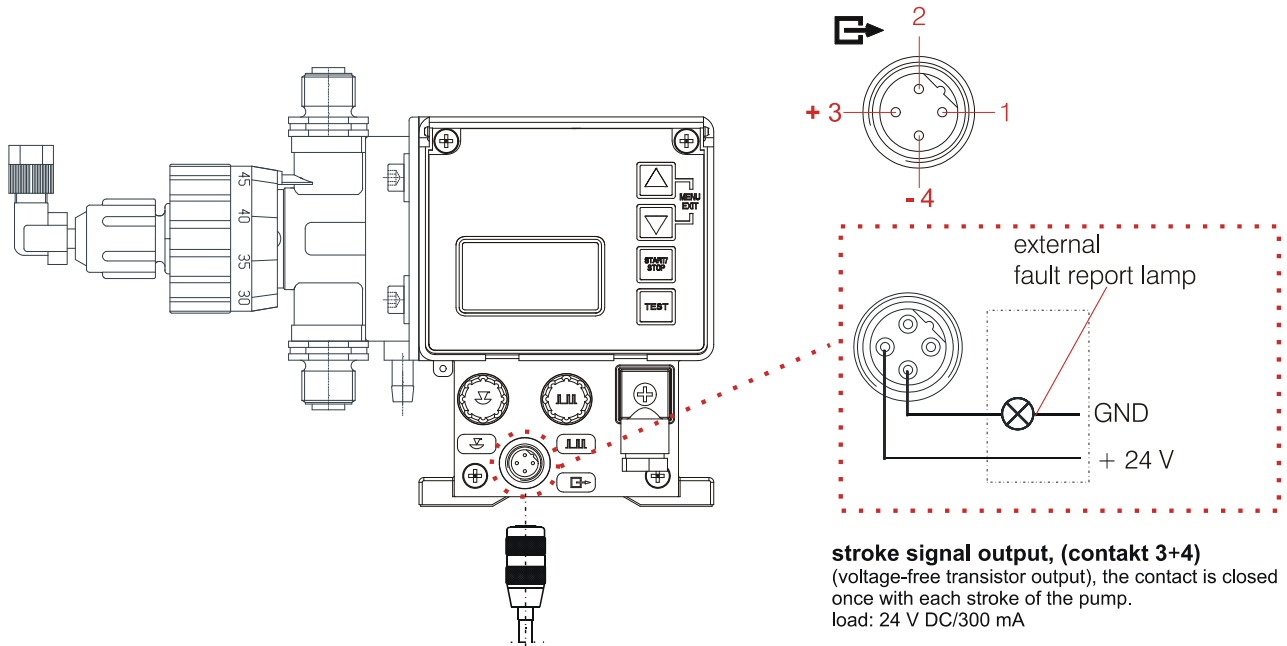

### 7.2.4.3 Installing the alarm output at 115/230 V / AC

Fig. 7.20

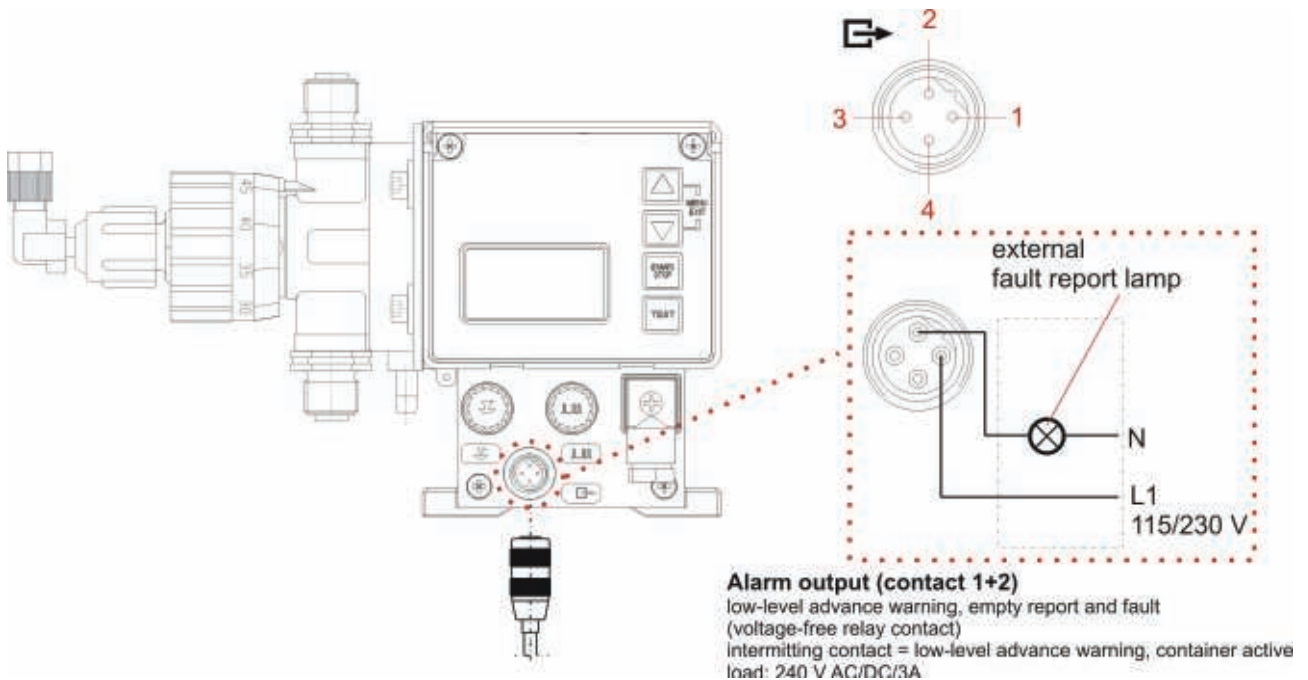

Standard configuration:

closed = empty report container active or error message

Other configuration see chapter [7.2.4.4](#) (Hardware) and chapter [10.3.9](#) (software /menu)

**! WARNING** At 115V/230 V, a simultaneous connection of contact 1/2 (alarm output) and 3/4 (stroke signal output) is generally not permitted.

### 7.2.4.4 Hardware migration for alarm contact

An alarm relay with a two-way contact is installed in the pump.

Depending on the position of the jumper, both the NC and the NO contact can be selected as the alarm contact.

To switch, please set jumper 3 from Pin 1 & 2 up to Pin 2 & 3.

Fig. 7.21

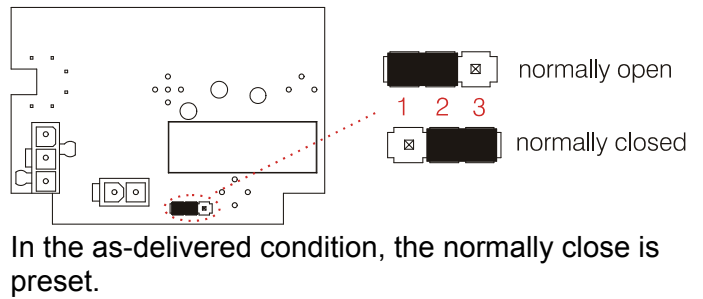

**NOTE**

**WARNING:**

Changes to the circuit board may only be performed by service personnel of the company ECOLAB-Engineering or trained technical personnel!

#### 7.2.4.4.1 In the alarm output "ON" ● configuration setting

(See Menu Description in chapter [10.3.9](#))

Jumper	If "No Alarm" (Alarm relay has not pulled in)	If "Alarm" (Alarm relay has pulled in)	Power Off (Alarm relay has not pulled in)
<b>Closing function:</b> (Default setting)	contact open	contact closed	contact open
<b>Opening function:</b>	contact closed	contact open	contact closed

#### 7.2.4.4.2 In the alarm output "OFF" ○ configuration setting

(See Menu Description in chapter [10.3.9](#))

Jumper	If "No Alarm" (Alarm relay has pulled in)	If "Alarm" (Alarm relay has not pulled in)	Power Off (Alarm relay has pulled in)
<b>Closing function:</b> (Default setting)	contact closed	contact open	contact open *
<b>Opening function:</b>	contact open	contact closed	contact closed

\* fail-safe function, (safe in the event of failure)

### 7.2.5 Connector assignments of slot IV, mains power supply

Fig. 7.22

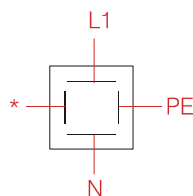

The mains power supply enters through a four-terminal frontal plug connector. This already has a plug screwed into it in the factory.

	color
L1 Mains / external conductor	brown
N Neutral wire	blue
PE Protective earth wire	yellow/green
* Not assigned	



**NOTE**

To ensure the imperviousness of the mains power connection to humidity, the gasket (contained in the delivery scope and already built-in in the as-delivered condition) must be inserted and the fixing screw tightened into the middle of the plug.

✂ Connect the mains power supply cable to the power grid.

## 8 Upgrading the EMP KKS E60 to the EMP KKS E60<sup>PLUS</sup>

To upgrade the EMP KKS E60 to the EMP KKS E60<sup>PLUS</sup> and thus access the additional functions, obtain the dongle box from our range of accessories. (Part No. 248606).

### 8.1 Fitting the dongle box

Fig. 8.1

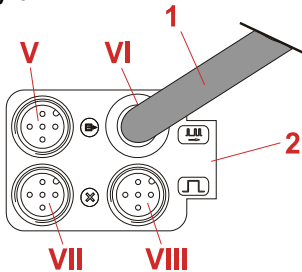

Pos.	Description
V	input for oval gear meter
VI	Fixed connector cable for connecting the pulse input to the EMP pump (input II)
1	Connection wire for connection to input II of the pump
2	Dongle box
VII	input for batch pulse and metering lock
VIII	input for pulse, standard signal input and metering lock

Fig. 8.2

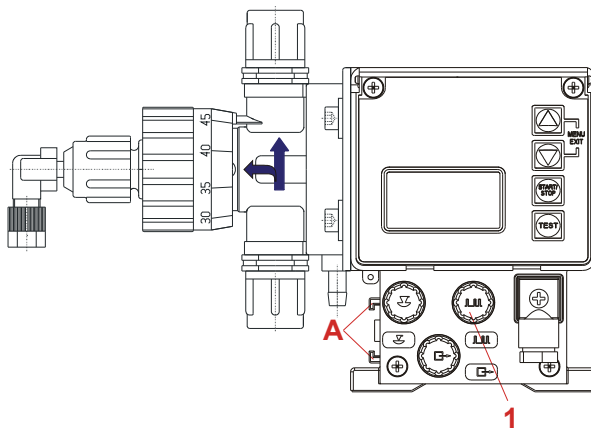
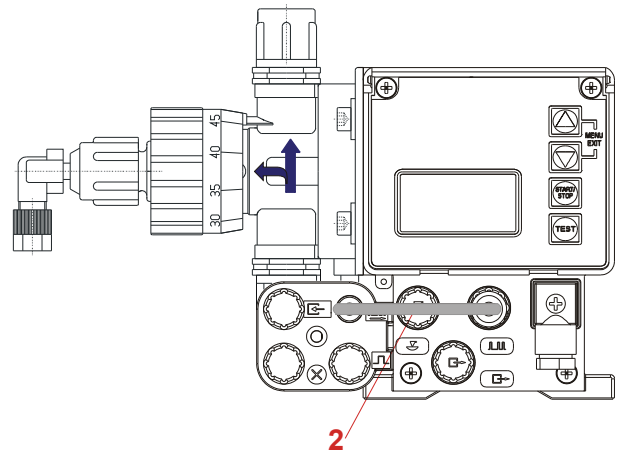

Fig. 8.3



Fit the dongle box (Fig. 8.1) to the rail of the EMP pump provided for this purpose (Fig. 8.2, pos. A):

- ✘ Slide the dongle box (Fig. 8.1) onto the rail on the left side of the EMP pump (Fig. 8.2, pos. A), until it snaps into place.
- ✘ Connect the connection cable (Fig. 8.1, pos. 3 and 8.3, pos. 2) to the input for pulse / standard signal (Fig. 8.2, pos. 1).
- ✘ Switch the pump off and afresh on.

The additional functions in the metering pump electronics can thus be activated and executed.



#### NOTE

If, before upgrading with a dongle box, a plug is connected to the input for pulse / standard signal (see Fig. 8.2, pos. 1), then this plug can be connected after the upgrade to plug VIII (see Fig. 8.1, pos. VIII) of the dongle box.

## 8.2 Connector assignments of the slots

### 8.2.1 Connector assignments of slot V (5-terminal), input for oval gear meter

Fig. 8.4

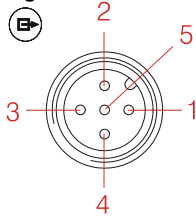

- 1: Supply for oval gear meter 5 V
- 2: Pulse input for oval gear meter, type OGM/OGC (standard)
- 3: Pulse input for oval gear meter, type OGM<sup>PLUS</sup>
- 4: GND
- 5: Free for future use

✘ Remove the protective cap

✘ Mount the connector plug according to the connector assignment.



**WARNING** Only use a connector plug from our product range!

#### 8.2.1.1 Installing the oval gear meter

Fig. 8.5

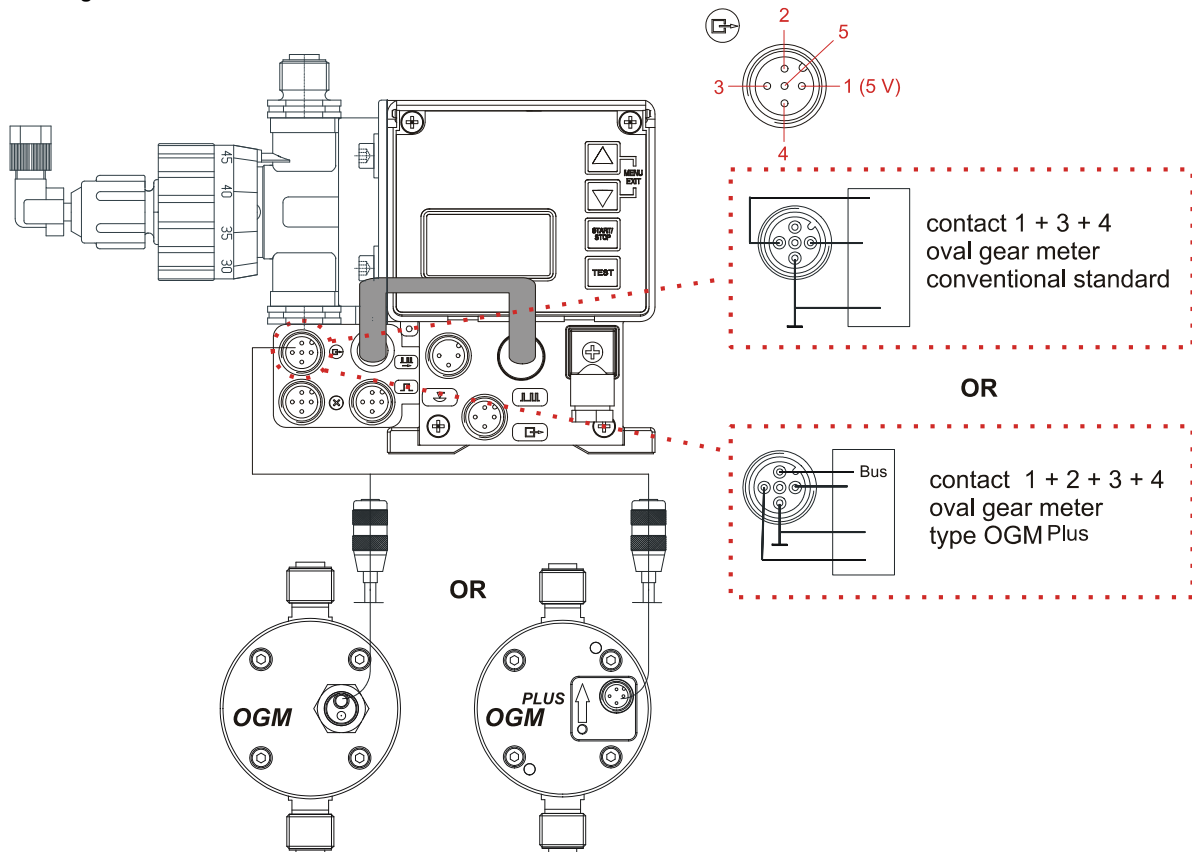



## 8.2.2 Connector assignments of Slot VII (5-terminal) input for batch pulse and metering lock

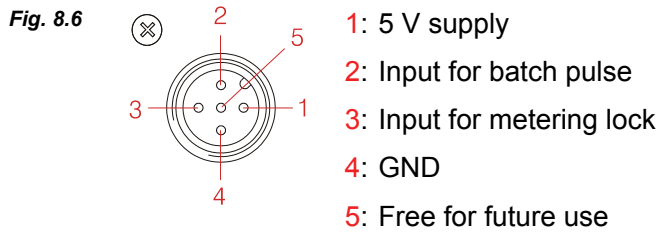

✘ Remove the protective cap

✘ Mount the connector plug according to the connector assignment.



**WARNING** Only use a connector plug from our product range!

### 8.2.2.1 Installing the batch pulse



#### HINWEIS

The batch function must be activated in menu first.  
(see chapter: [10.3.15](#) batch configuration)

According to the requirements, the input of the batch pulse (contact 2+4 or contact 3+4) must be configured. (see chapter [10.3.15](#).)

Fig. 8.7

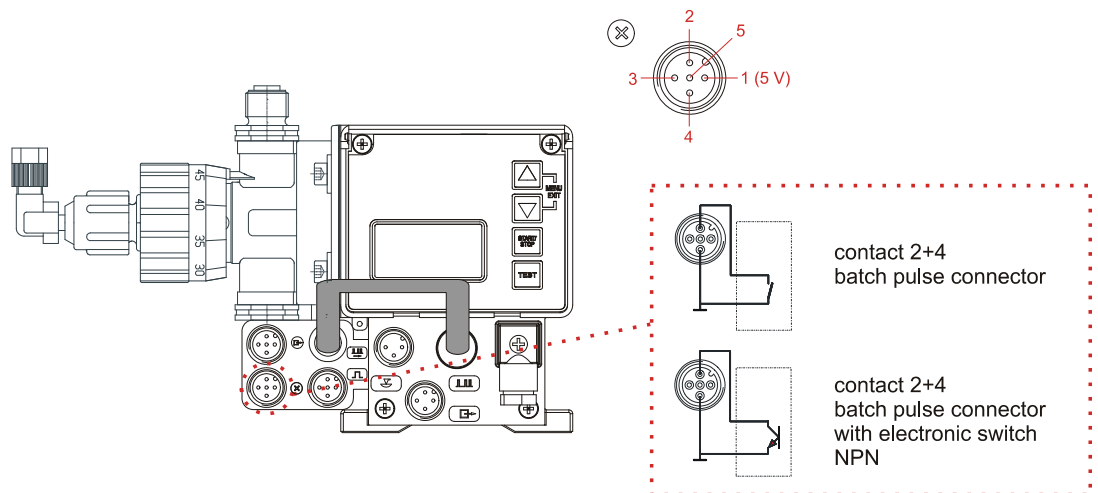

### 8.2.2.2 Installing the metering lock (optional connector VII or VIII)

 **HINWEIS** The metering lock function must be activated in menu first.  
(see chapter: [10.3.7](#) configuration meterin lock)  
The metering lock is available in all operation modes.

Fig. 8.8



### 8.2.3 Connector assignments of Slot VIII (5-terminal) input for pulse, standard signal input and metering lock

Fig. 8.9

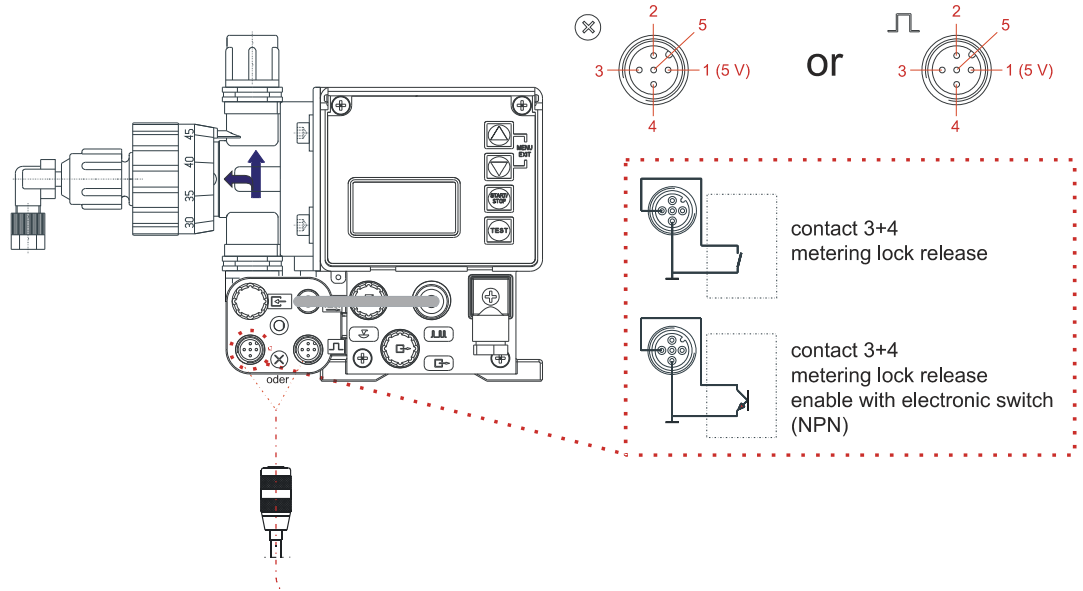
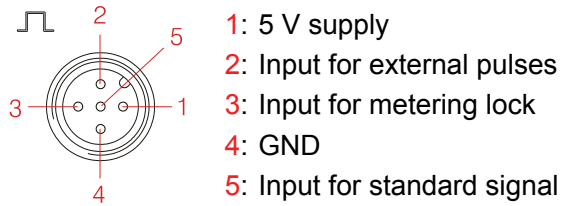

✘ Remove the protective cap

✘ Mount the connector plug according to the connector assignment.



**WARNING** Only use a connector plug from our product range!

#### 8.2.3.1 Installing the pulse control (water meter)

Fig. 8.10

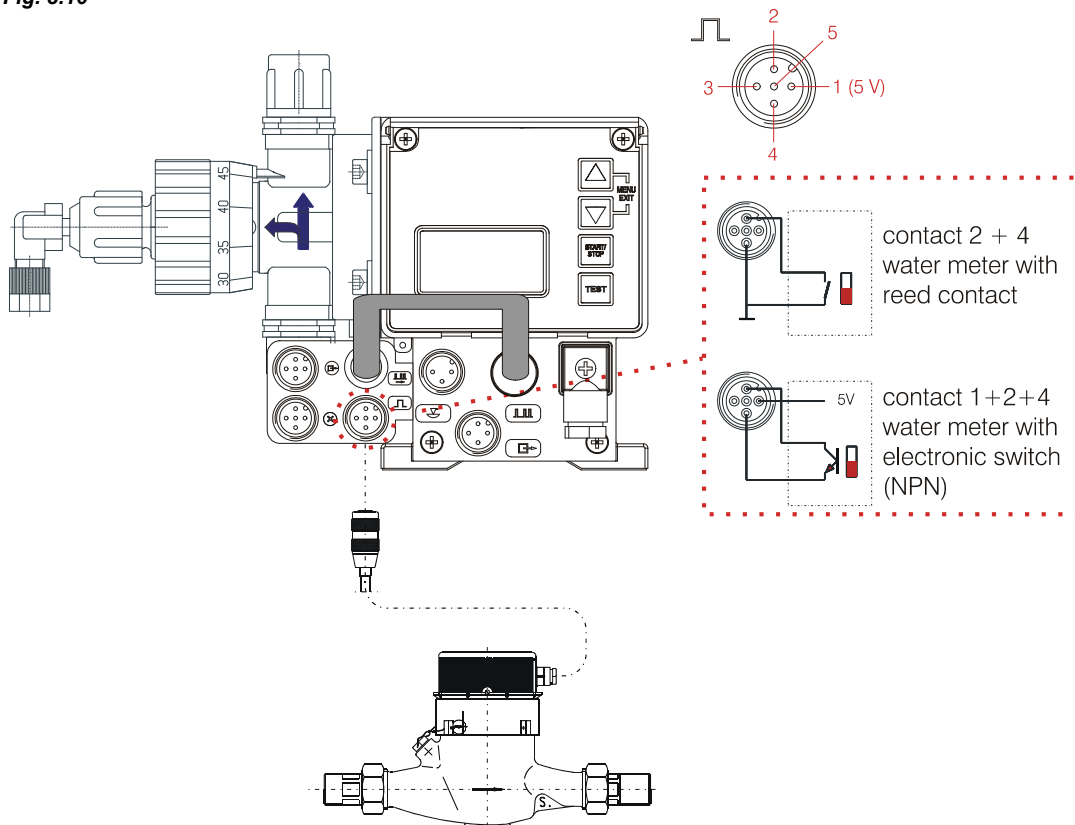

### 8.2.3.2 Installing the standard signal (mA)

Fig. 8.11

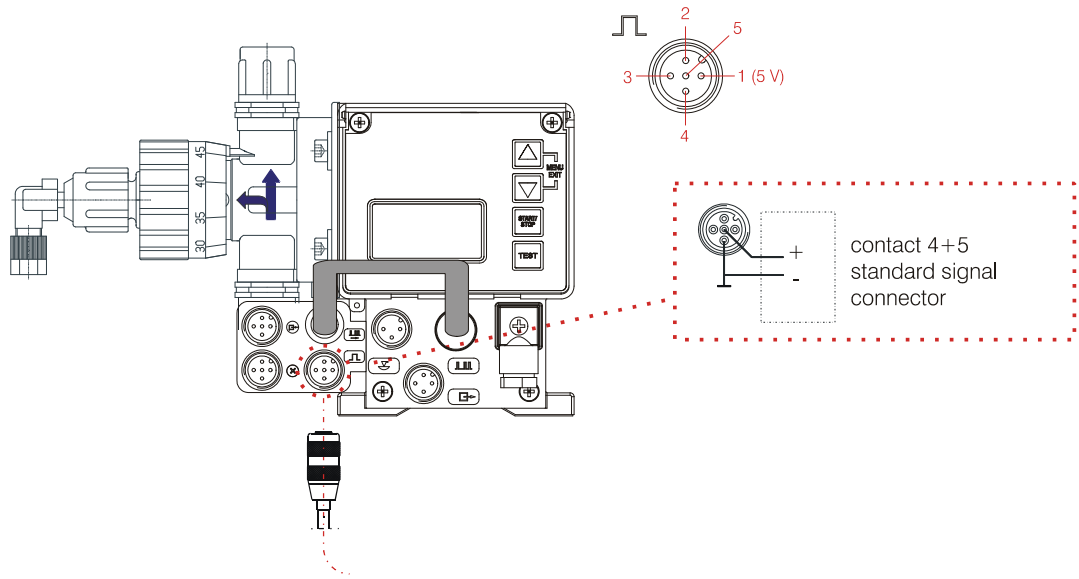

### 8.2.3.3 Installing the metering lock



**HINWEIS**

The metering lock function must be activated in menu first.  
 (see chapter: [10.3.7](#) configuration meterin lock)

The metering lock is available in all operation modes.

Fig. 8.12

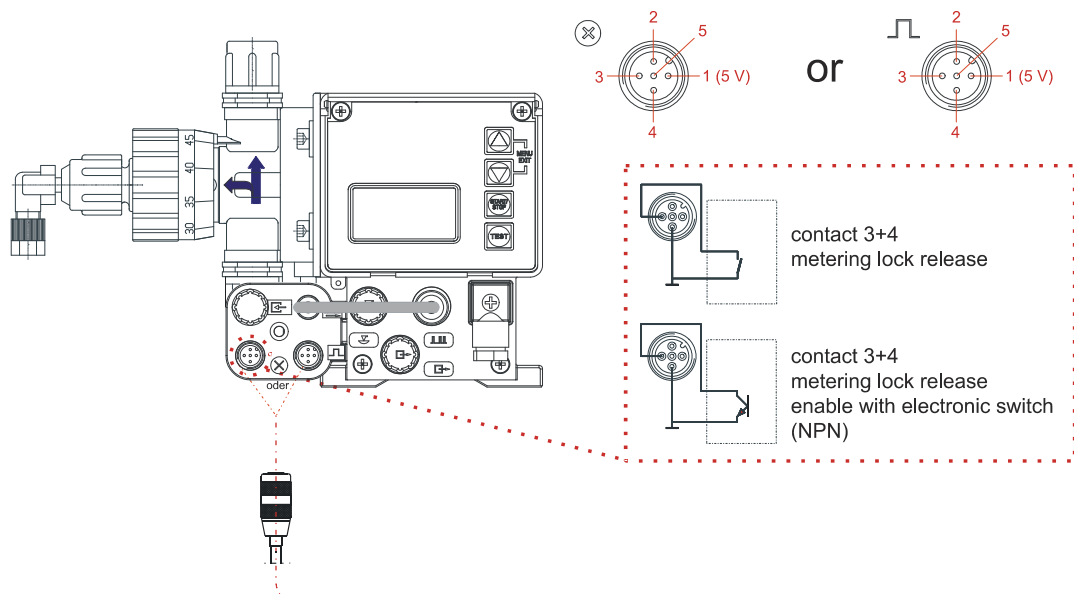

## 9 Startup

### 9.1 Switching on the pump

Fig. 9.1



2 sec ✕ Press START/STOP key (min. 2 sec.).

### 9.2 Switching off the pump

Fig. 9.2



5 sec ✕ Press START/STOP key (min. 5 sec.).

### 9.3 Key functions

Key	Description
<p>Fig. 9.3</p>	<p>MENU/EXIT function entry and exiting of the menu levels (keep keys pressed down together)</p> <p>(▲) Modify set values upwards</p> <p>(▼) Modify set values downwards</p>
<p>Fig. 9.4</p>	<p>Start the pump</p> <p>Stop the pump</p> <p>Confirmation key (ENTER) for set values</p>
<p>Fig. 9.5</p>	<p>Test function (endurance test)</p>

### 9.4 Initial startup / Delivery status

In the as-delivered condition, the pump is configured as follows.

Operation mode: Internal

Stroke frequency: 122 strokes/min (max. at 50 Hz) or 146 strokes/min (max. at 60 Hz)

Status: pump in the "OFF" ("Standby" in V 4.0) operating state



#### NOTE

To change the preconfigured factory settings, observe the corresponding menu items in chapter [10.3](#) "Configuration".

### 9.4.1 Software version display

Fig. 9.6

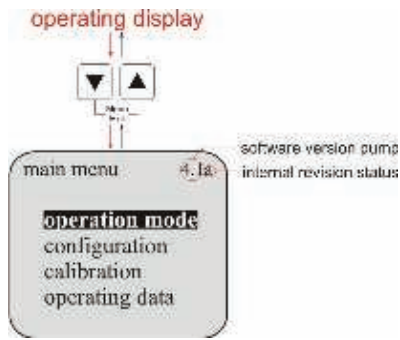

The current software version is displayed in the top right of the main menu screen (Fig. 9.6).

Lowercase letters after the software number (Fig. 9.6) describe internal software modifications that do not affect the operation of the device.

Fig. 9.7

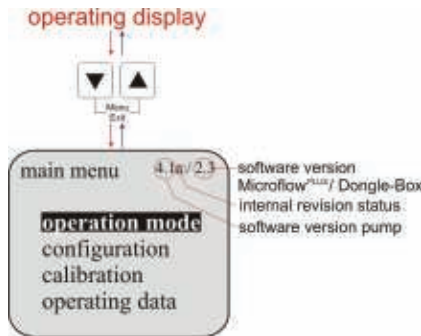

If a dongle box or a MicroFlow<sup>PLUS</sup> has been connected, the unit version (Fig 9.7) is displayed to the right of the pump version.

### 9.4.2 Display at operating display

On delivery, the following basic factory settings appear on the display when the main voltage is switch on.

Fig. 9.8

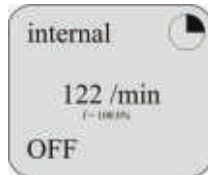

- Operating mode:** internal
- Metering frequency / - quantity:** strokes/min  
(122 strokes/min at 50 Hz,  
146 strokes/min at 60 Hz)
- Operating state:** OFF (in V 4.1, „Standby“ in V4.0  
(to start the pump press  
START / STOP key)

**NOTE** With each stroke of the pump, the indicator in the upper right of the display rotates 1 turn.

### 9.4.3 Configuration

The following factory settings are defined in the configuration.

Fig. 9.9

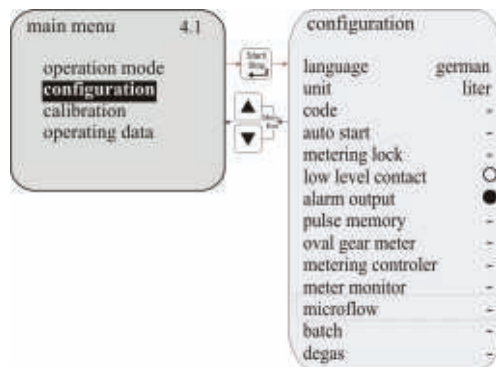

Configuration of	Standard	Chapter
<b>language:</b>	German	see <a href="#">10.3.3</a>
<b>unit:</b>	liter	see <a href="#">10.3.4</a>
<b>code:</b>	not active (-)	see <a href="#">10.3.5</a>
<b>auto start:</b>	not active (-)	see <a href="#">10.3.6</a>
<b>metering lock:</b>	not active (-)	see <a href="#">10.3.7</a>
<b>low level contact:</b>	open (O)	see <a href="#">10.3.8</a>
<b>alarm output:</b>	off (●)	see <a href="#">10.3.9</a>
<b>pulse memory:</b>	not active (-)	see <a href="#">10.3.10</a>
<b>oval gear meter:</b>	not active (-)	see <a href="#">10.3.11</a>
<b>metering controller:</b>	not active (-)	see <a href="#">10.3.12</a>
<b>meter monitor:</b>	not active (-)	see <a href="#">10.3.13</a>
<b>microflow:</b>	not active (-)	see <a href="#">10.3.14</a>
<b>batch:</b>	not active (-)	see <a href="#">10.3.15</a>
<b>degas:</b>	not active (-)	see <a href="#">10.3.16</a>

**microflow:** Only appears on the display in conjunction with the MicroFlow<sup>PLUS</sup> metering monitor, which is available as an accessory.

## 10 Menu description

### 10.1 Main menu

The main menu can be accessed while the pump is operating.

It is started by simultaneously pressing the ▲ and ▼ keys.

Simultaneously press the ▲ and ▼ keys again to return to the operating display.

#### 10.1.1 Overview

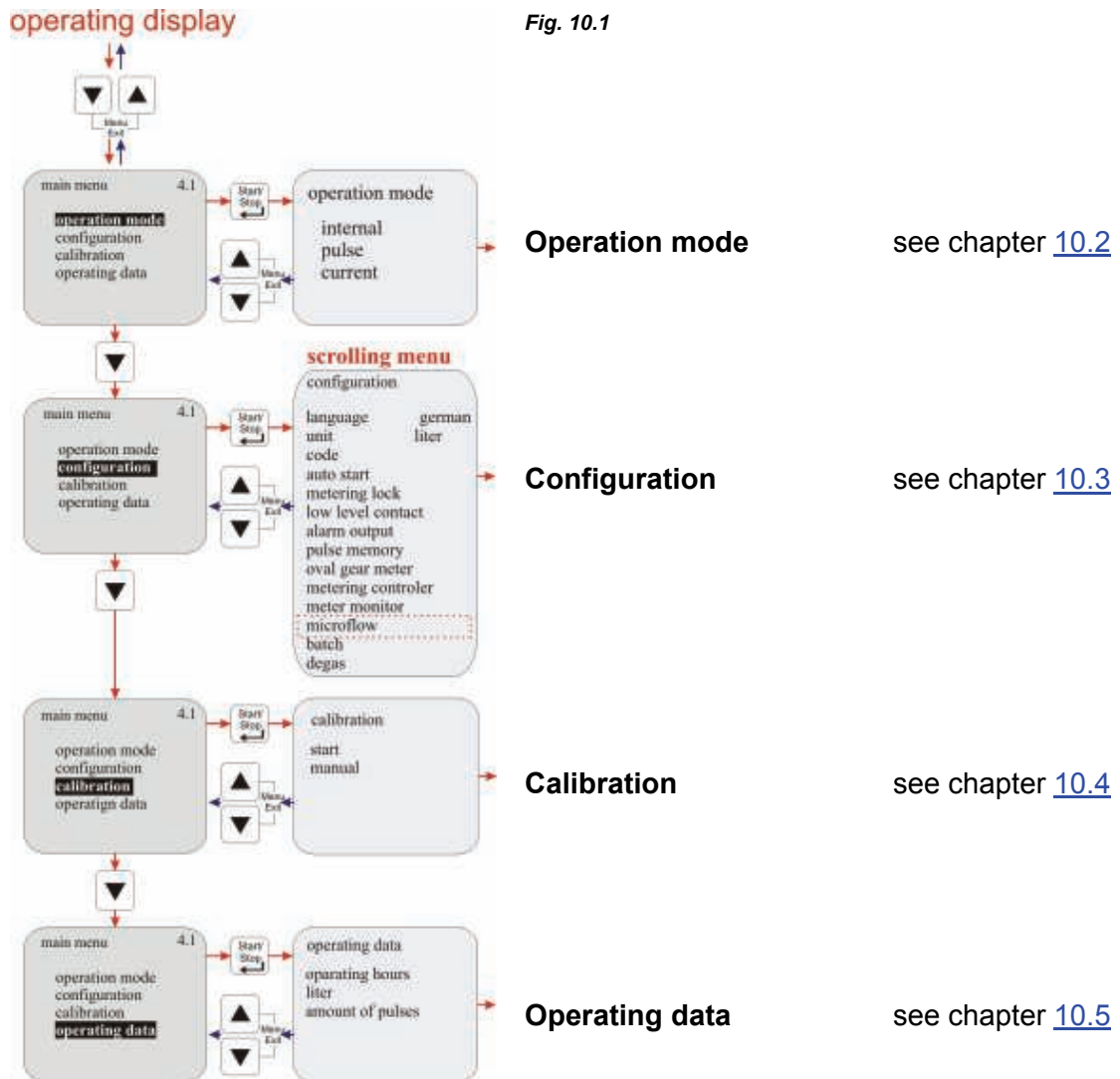

## 10.2 Operation mode

### 10.2.1 Selecting

Fig. 10.2 **operating display**

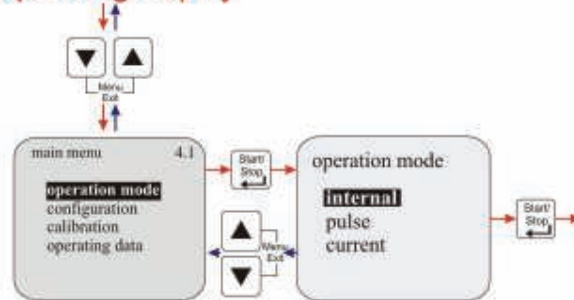

#### Adjustments:

- internal      chapter [10.2.2](#)
- pulse        chapter [10.2.3](#)
- current      chapter [10.2.4](#)

### 10.2.2 Operation mode / internal

The “internal” operation mode can be used to operate the metering pump without external signals.

#### The following display options can be selected:

- **Strokes/min**      The configured metering speed (and thus the metering rate) is displayed in strokes/min. (**Default setting**)
- **Percent**            The configured metering speed (and thus the metering rate) is displayed as a percentage.
- **Liter\***                The configured metering rate is displayed in litres/h (optionally also in gallons/day or gallons/h).  
For information on converting litres to gallons, see [10.3.4](#)

#### 10.2.2.1 Selecting

Fig. 10.3 **operating display**

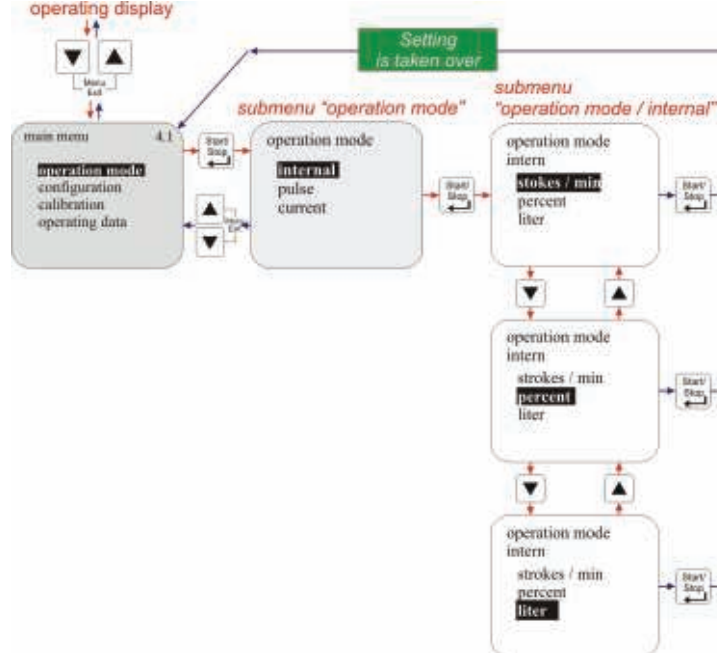



### 10.2.2.2 Display in the operating display/ Setting

The metering rate can be configured/adjusted in the operating display during operations.

 **NOTE** If the newly set value is not confirmed within 10 seconds by pressing the START/STOP key, the system reverts to the primarily value.

**Strokes/min**

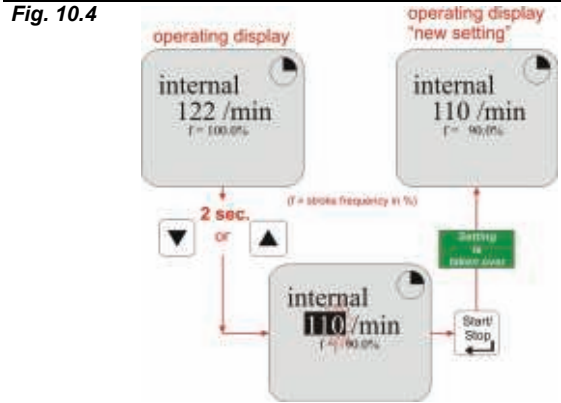

**Percent (%)**

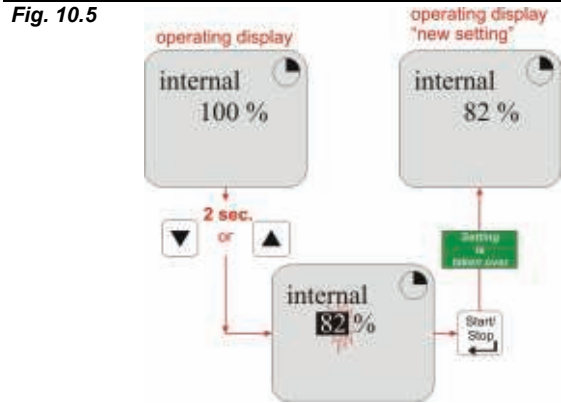

**Liter/min**

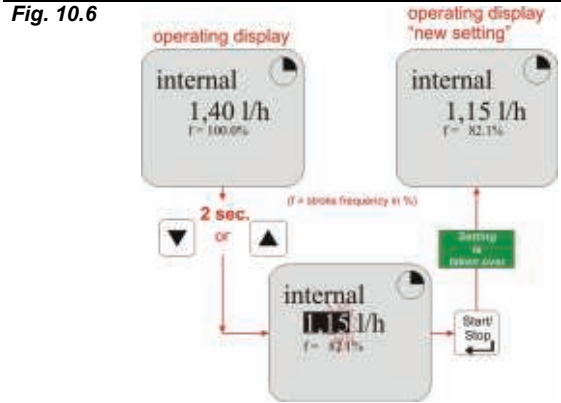

**Gallons/day**

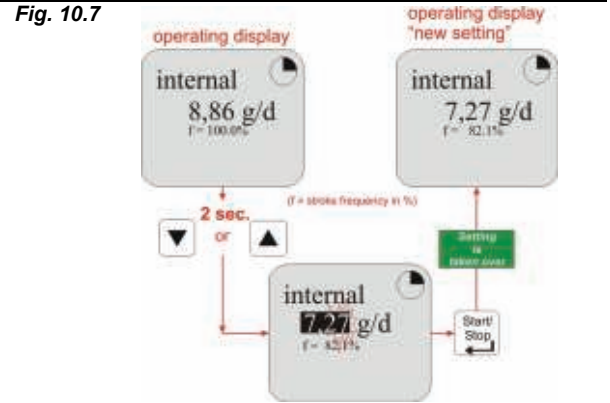

### 10.2.3 Operation mode / pulse

For the “pulse” operation mode, the metering pump only works in conjunction with incoming pulses (e.g. from a contact water meter).

**The following pulse processing options can be selected:**

- **Multiplication** Incoming pulses are multiplied by a configurable factor (n):  
**1 pulse = n pump strokes (default setting)**
- **Division** Incoming pulses are divided by a configurable factor (n):  
**n pulse = 1 Pumpenstroke**

### 10.2.3.1 Selecting

Fig. 10.8

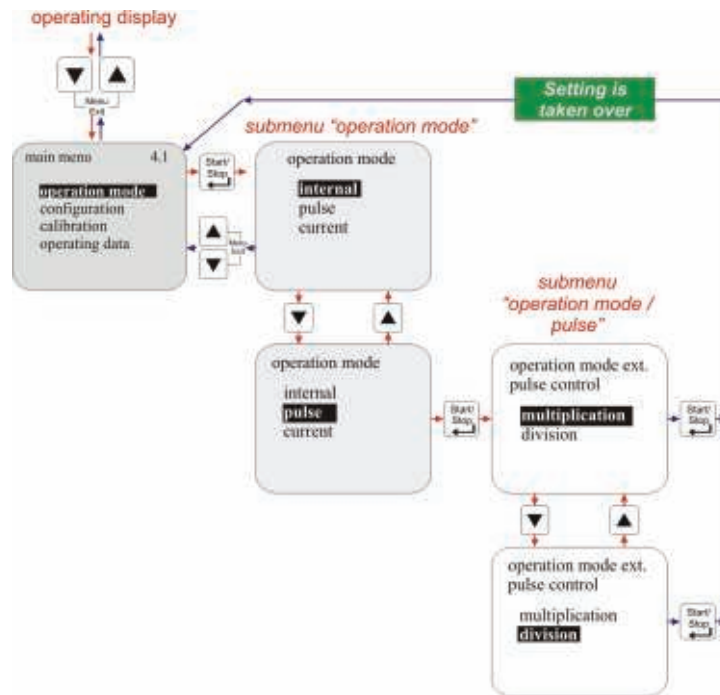

### 10.2.3.2 Display in the operating display/ Setting

The multiplication and division factors are configured/adjusted in the operating display. This can take place while the pump is operating.

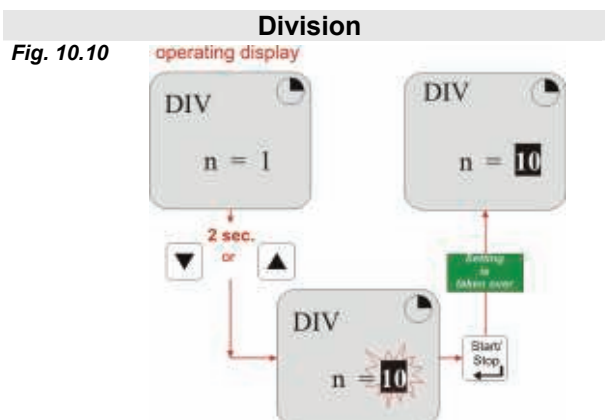
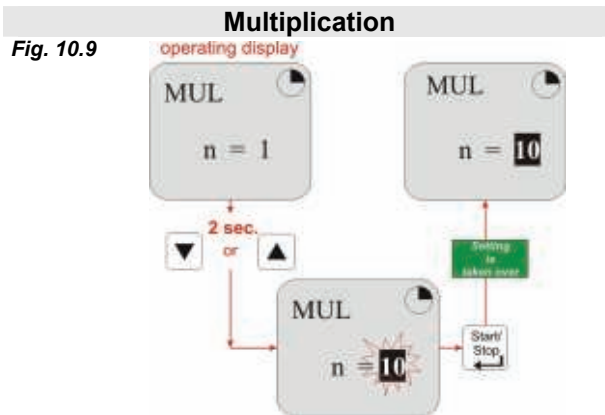

**NOTE**

If the newly set value is not confirmed within 10 seconds by pressing the START/STOP key, the system reverts to the previously set running value.

### 10.2.4 Operation mode / current (external standard signal)

In the “current” operation mode, the pump functions on the basis of an incoming standard signal. The incoming signal (0/4-20 mA; 20-0/4 mA or adjustable) is converted into a metering frequency 0-100 % (stroke/pause ratio), e.g.:

**The following operating options can be selected:**

- **0 – 20 mA**      0 mA = 0% metering frequency, 20 mA = 100 % metering frequency
- **4 – 20mA**      4 mA = 0% metering frequency, 20 mA = 100 % metering frequency
- **20 – 0 mA**      20 mA = 0% metering frequency, 0 mA = 100 % metering frequency
- **20 – 4 mA**      20 mA = 0% metering frequency, 4 mA = 100 % metering frequency
- **User defined**    n (adjustable) mA = 0 % metering frequency,  
n (adjustable) mA = 100 % metering frequency

#### 10.2.4.1 Selecting

Fig. 10.11

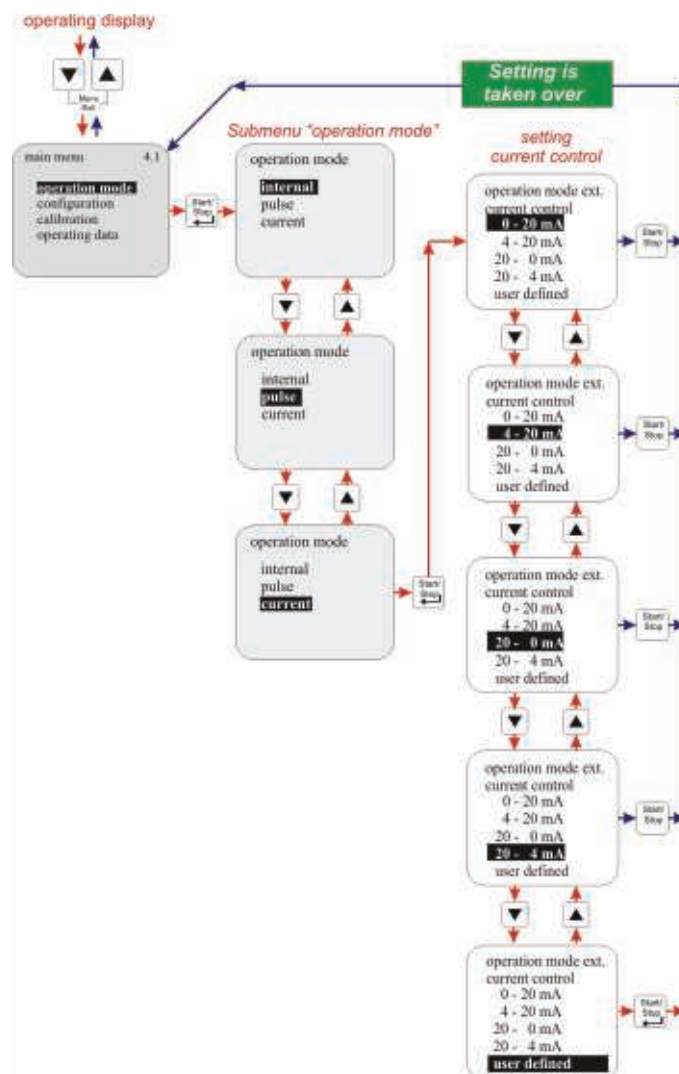

See chapter [10.2.4.1.1](#)

### 10.2.4.1.1 Setting operation mode / current / user defined

**NOTE** The difference in the set values must be greater than or equal to 5. (e.g. min 10 max 15).

Fig. 10.12

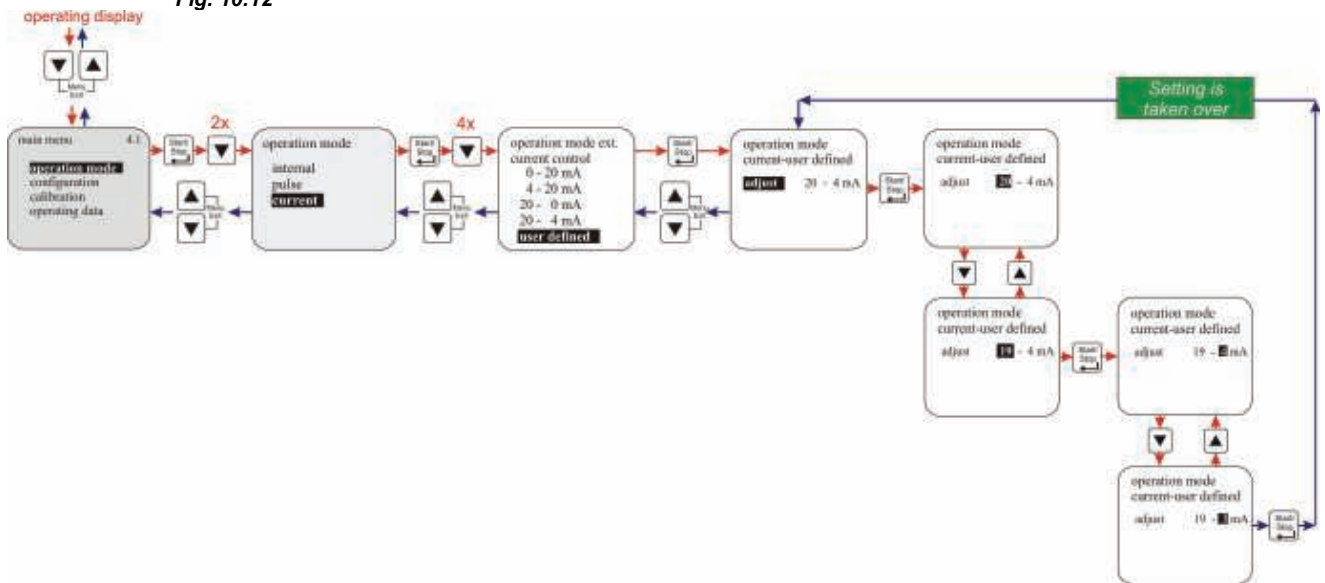

### 10.2.4.2 Display in the operating display

Display	Pos	Description
	1	Range of input signal, preset in the menu
	2	Actual connected current value
	3	Stroke frequency in %

Fig. 10.13

## 10.3 Configuration

### 10.3.1 Overview

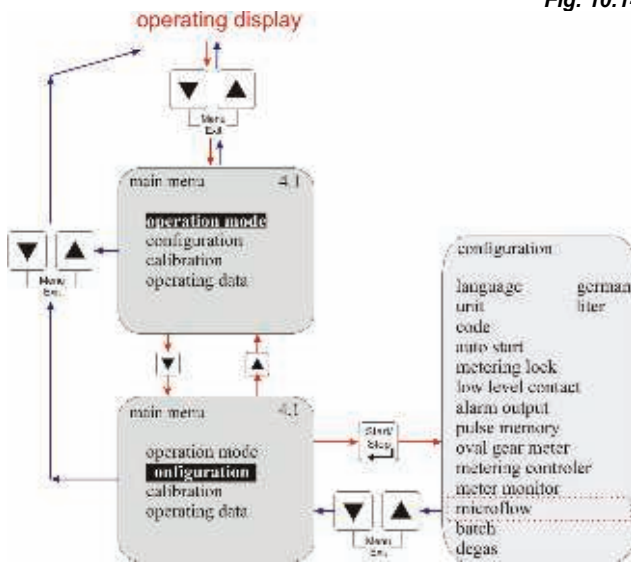

Fig. 10.14

#### Configuration of:

#### chapter:

- **Menu language** see [10.3.3](#)
- **Units** see [10.3.4](#)
- **Code entry** see [10.3.5](#)
- **Startup settings** see [10.3.6](#)
- **Metering lock** see [10.3.7](#)
- **Low-level contact** see [10.3.8](#)
- **Alarm output** see [10.3.9](#)
- **Pulse memory** see [10.3.10](#)
- **Oval gear meter** see [10.3.11](#)
- **Metering controller** see [10.3.12](#)
- **Metering monitoring** see [10.3.13](#)
- **MicroFlow** see [10.3.14](#)  
This menu item only appears in conjunction with the MicroFlow metering monitor, which is available as an accessory, and replaces the menu item "metering monitoring".
- **Batch** see [10.3.15](#)
- **Degas** see [10.3.16](#)

### 10.3.2 "Scrolling the display"

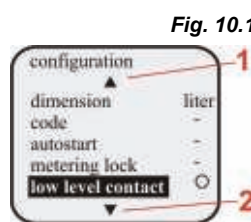

Fig. 10.15

The display possesses a "scroll function", i.e. some menu items are only shown on the display when the end of the menu is reached on the display.

Using the symbols ▲ (1) or ▼ (2) on the display, you can see which direction you can scroll in.

- 1 = (▲)scroll the display upwards
- 2 = (▼)scroll the display downwards

### 10.3.3 Configuration / Language

This is used to select the menu language.

#### 10.3.3.1 Selecting

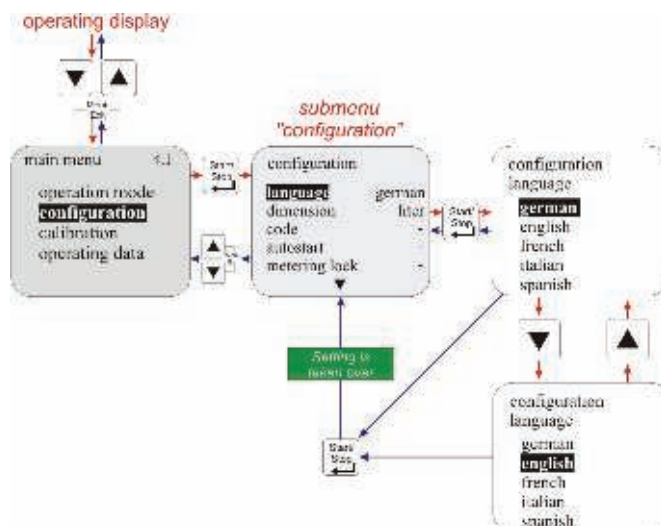

Fig. 10.16

**Default setting = German**

### 10.3.4 Configuration / Unit

If 'litre' is selected for the 'internal' operation mode (see chapter [10.2.2](#)), this can be used to change the display from litres/h to gallons/day (**1 gallon = 3,785 litres**).

#### 10.3.4.1 Selecting

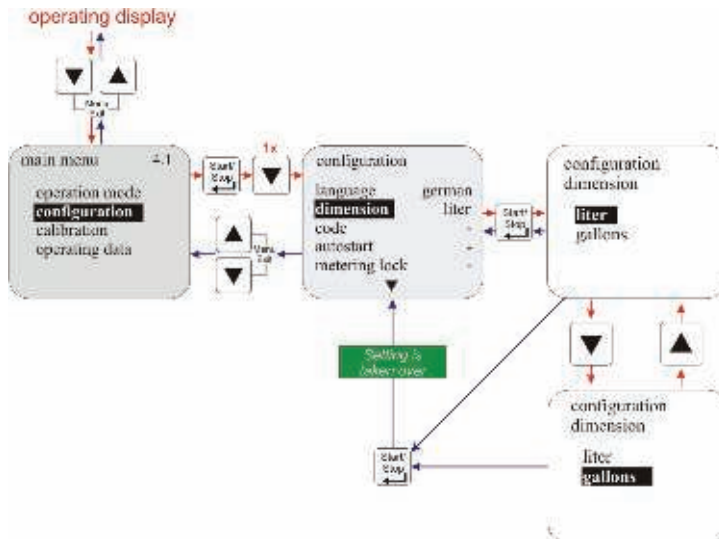

Fig. 10.17

**Default setting = liter**

### 10.3.5 Configuration / Code

With this setting, a four-digit number combination can be assigned to secure the setting against unauthorized adjustment.

If 'code' has been activated, the four-digit code must be entered before configured values can be amended or the main menu can be accessed.

#### 10.3.5.1 Selecting

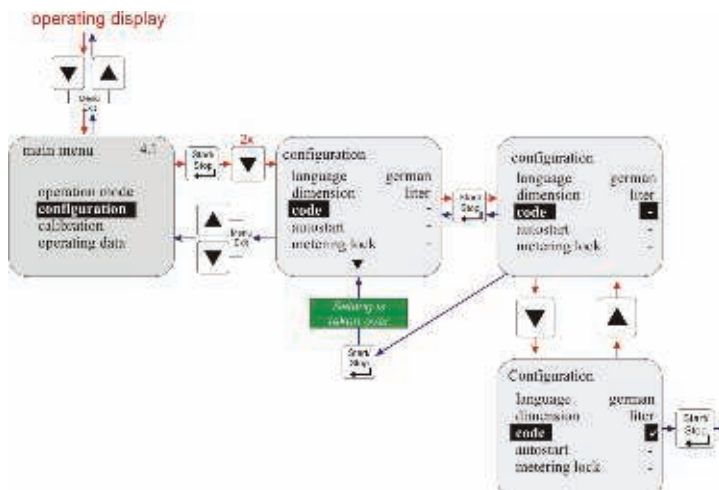

Fig. 10.18

- Code query inactive. (Default setting)
- ✓ Code query active.

see chapter [10.3.5.2](#)

### 10.3.5.2 Setting

Fig. 10.19

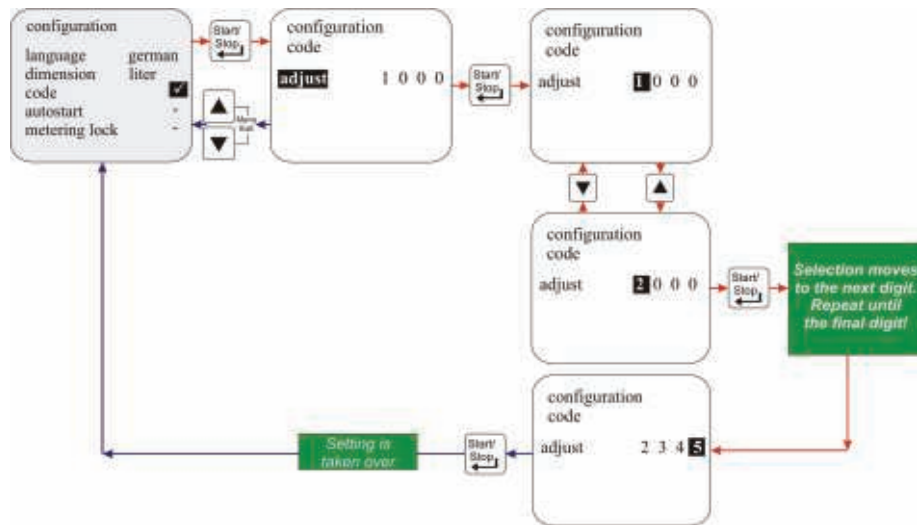

### 10.3.6 Configuration / Autostart

This function determines whether the pump is set to 'OFF' ('Standby' in V 4.0) when the mains connection is re-established following a power cut or if the pump should immediately recommence functioning in the configured operation mode.

#### 10.3.6.1 Selecting

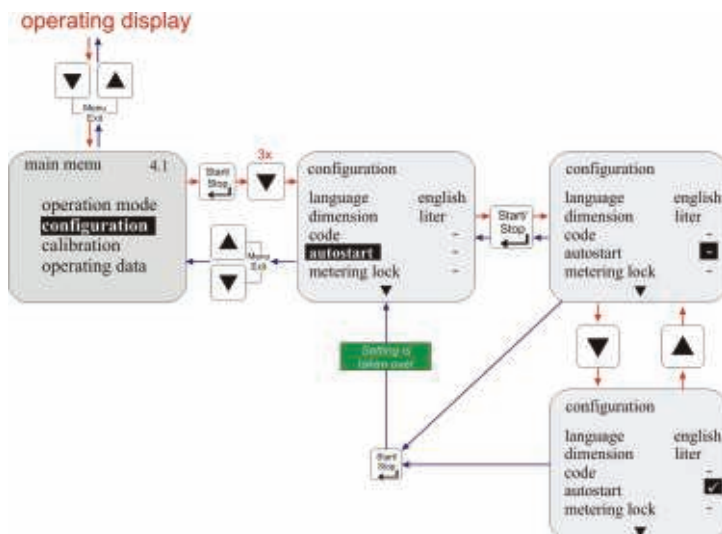

Fig. 10.20

- **autostart ist inactive.**  
When the mains voltage is connected, the pump always enters the "OFF" ("Standby" in V 4.0) operating state. **(Default setting)**
- ✓ **autostart ist active.**  
When the mains voltage is connected, the pump starts functioning in the configured operation state.

### 10.3.7 Configuration / Metering lock

If the metering lock is enabled, the pump only functions if an external enable contact is connected to plug II between PINS 3+4 (see chapter [8.2.2.2](#)) (regardless of which operation mode is set).

### 10.3.7.1 Selecting

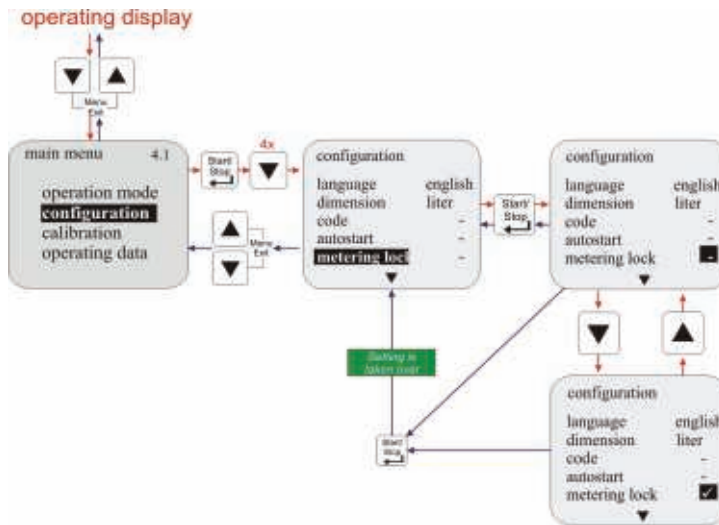

Fig. 10.21

- interrogation of the metering lock is inactive. (Default setting)
- ✓ interrogation of the metering lock is active.

### 10.3.8 Configuration / Low-level contact

This function specifies whether an open or a closed contact at the level input (plug I, see chapter 7.2.2.1) is regarded as level OK.

#### 10.3.8.1 Selecting

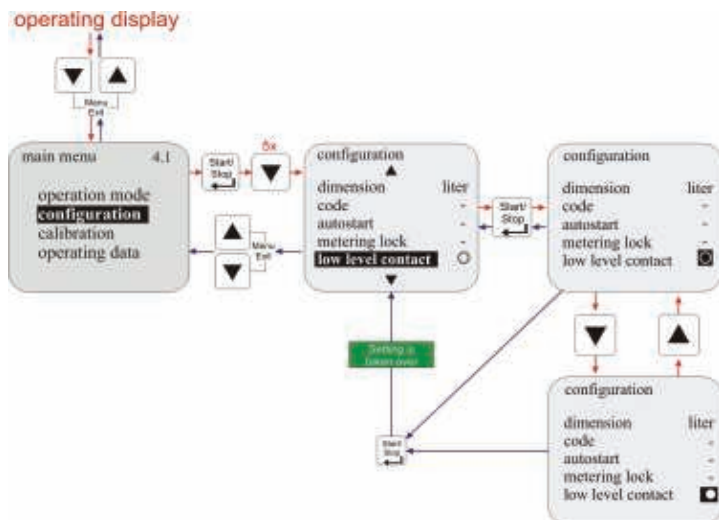

Fig. 10.22

- = contact open:  
level not OK (empty)
- = contact closed:  
level OK (full)  
(Default setting)
- = contact closed:  
level not OK (empty)
- = contact open:  
level OK (full)

### 10.3.9 Configuration / Alarm output

This option permits the inversion of the alarm output (alarm output relay has pulled in or not pulled in when the alarm was triggered).



### 10.3.9.1 Selecting

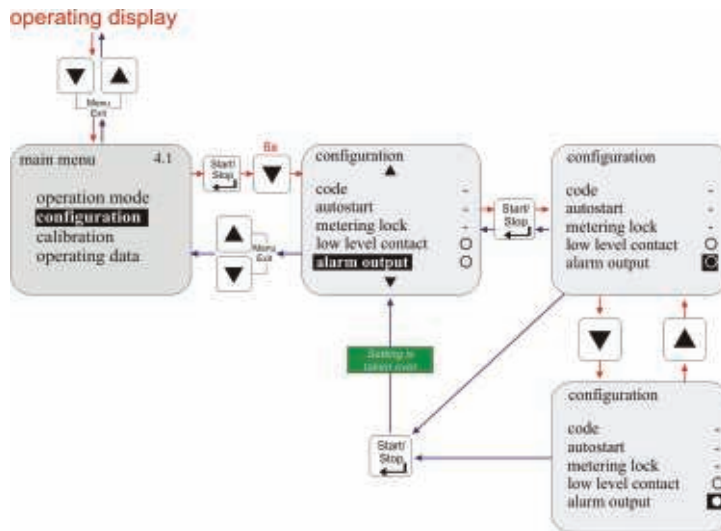

Fig. 10.23

- = When an alarm is triggered, the relay is pulled in for the alarm output. (Default setting)
- = When an alarm is triggered, the relay is not pulled in for the alarm output.

In addition to the function mode of the relay, it is also possible to select whether the alarm output relay contact is closed (closing function on, default setting) when the relay is pulled in or open (opening function) (see chapter 7.2.4.4 conversion from alarm relay mode to contact mode).

### 10.3.9.2 Conversion from alarm relay mode to contact mode.

See chapter [7.2.4.4](#)

### 10.3.10 Configuration / pulse memory

If the incoming pulse rate is higher than the maximum pulse rate that the pump can process (max. pump frequency e.g. 122 strokes/min at 50 Hz), the pulses that cannot be processed can be stored.

	<p><b>WARNING</b> The stored pulses are processed once no further external pulses are received. This means that the pump continues to function even though there is no external running condition. In the worst case, this can lead to metering taking place into a closed system and resulting in impermissibly high pressure in the system. This must be prevented through appropriate safety measures.</p>
---	---

The memory content is erased by activating the metering lock or switching off the pump.

### 10.3.10.1 Selecting

Fig. 10.24

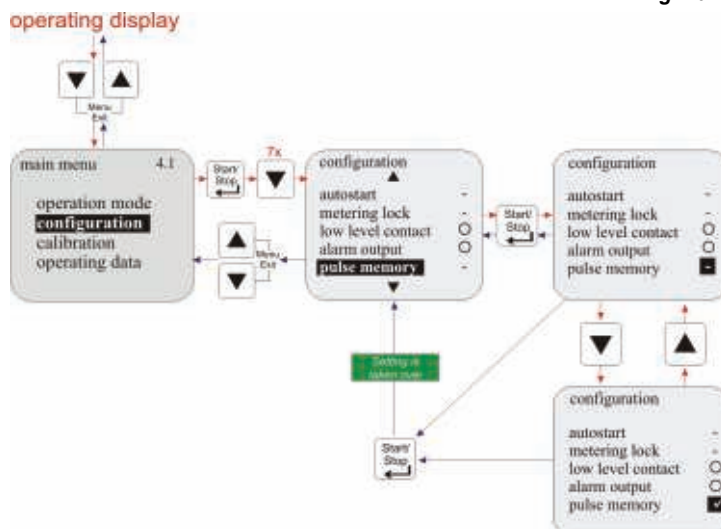

- pulse memory is inactive. (Default setting)
- ✓ pulse memory is active.

### 10.3.10.2 Display in the operating display with an active pulse memory

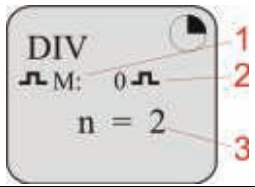
Display in operation	Meaning	Pos	Description
<b>Fig. 10.25</b> 	<b>Pulse multiplication</b>  (Example: 10 external pulses become 20 strokes)	1	Pulse memory active
		2	Number of pulses received
		3	Set factor
<b>Fig. 10.26</b> 	<b>Pulse division</b>  (Example: 10 external pulses become 20 strokes)	1	
		2	
		3	

### 10.3.11 Configuration / Oval gear meter (only E60<sup>PLUS</sup> & OGM or OGM<sup>PLUS</sup>)

The controller function of the EMP E60<sup>PLUS</sup> pump can be enabled using an OGM<sup>PLUS</sup> oval gear meter.

The oval gear meter function makes it possible to record a “real” value in the operating data/litre menu item (see chapter [10.5.3](#)).

	<b>NOTE</b>	<p>The oval gear meter can only be activated if the pump is upgraded with a <u>dongle box</u> to the E60<sup>PLUS</sup> and a “standard” oval gear meter (see Accessories) is connected.</p> <p>To activate the Dongle-Box in connection with the oval gear meter, the power supply has to be switched off and on again! (Unplug power plug or switch the pump off and back on again!)</p> <p>The oval gear meter function is automatically activated when an OGM<sup>PLUS</sup> is connected.</p>
---	-------------	--

#### 10.3.11.1 Selecting

Fig. 10.27

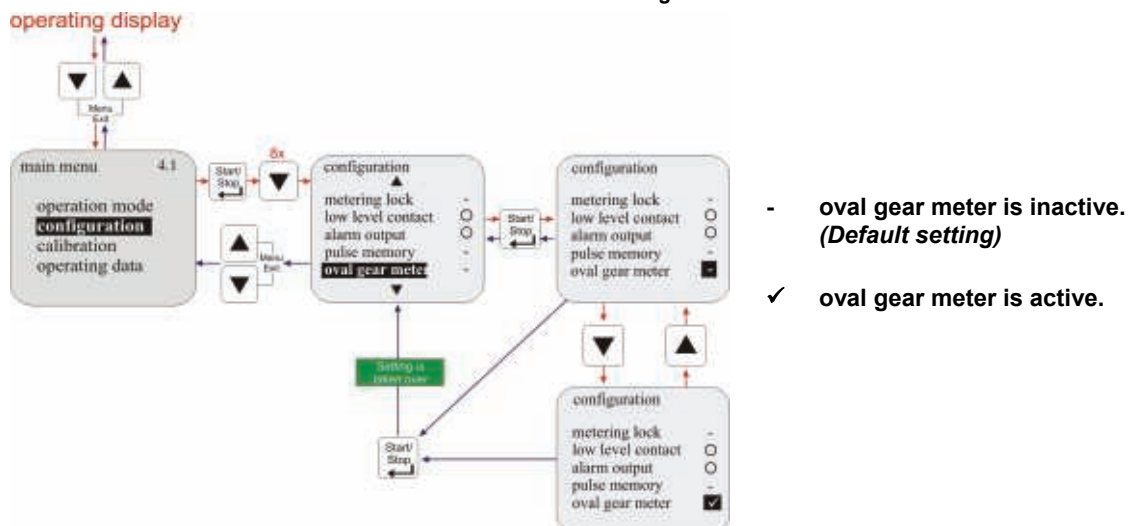

### 10.3.12 Configuration / Metering controller“ (only E60<sup>PLUS</sup> & OGM<sup>PLUS</sup>)

If the metering controller is active, in conjunction with the connection of an OGM<sup>PLUS</sup> for recording the metering rate, the pump’s metering performance in ‘internal’ and ‘current’ modes can be adjusted within the performance limits. I.e. if it is not possible to reach the set delivery rate due to external influences, then the metering frequency of the pump is automatically increased until the desired discharge flow is reached.

If external influences increase the feed rate by too much, the controller reduces the metering frequency.

	<p><b>NOTE</b></p>	<p>The metering controller function can only be activated if the pump is upgraded with a <b>dongle box</b> to the E60<sup>PLUS</sup> and oval gear meter, type OGM<sup>PLUS</sup> (see Accessories) is connected.</p> <p>To activate the Dongle-Box in connection with the oval gear meter, the power supply has to be switched off and on again!</p>
---	--------------------	---

#### 10.3.12.1 Selecting

Fig. 10.28

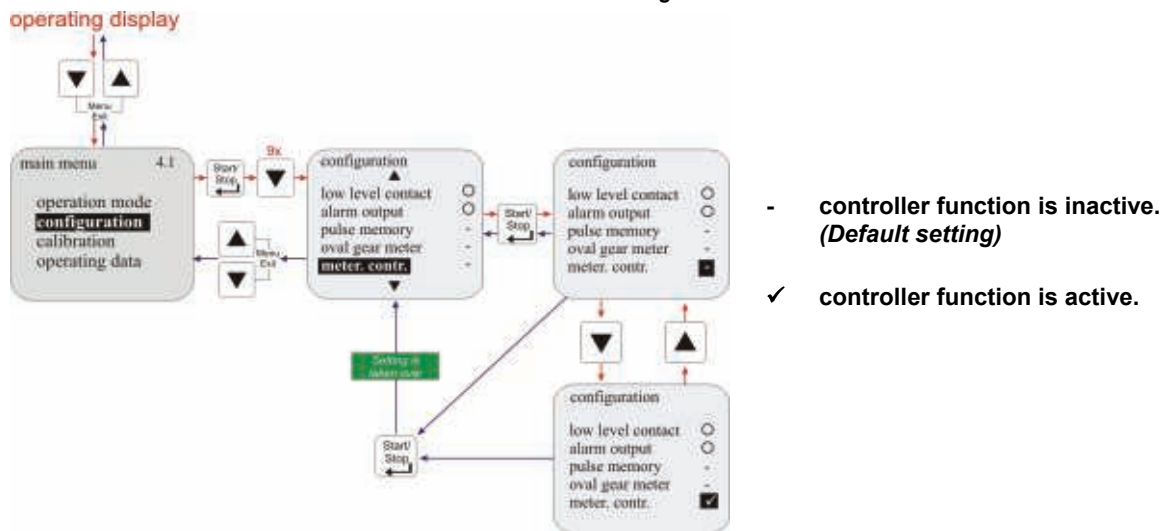

### 10.3.12.2 Display in the operating display with an active metering controller

Fig. 10.29



▼ = Downward metering divergence

The pump is currently delivering less than the preset stroke frequency (here 100/min for example) requires.

Metering frequency is increased automatically until the actual value matches the target value.

Fig. 10.30



- = No metering divergence

The pump delivers exactly the preset flow (here 100/min for example).

No correction is necessary.

Fig. 10.31



▲ = Upward metering divergence

The pump is currently delivering more than the preset stroke frequency (here 100/min for example) requires.

Metering frequency is reduced automatically until the actual value matches the target value.

**NOTE** Fig. 10.32

→ Dongle-box mounted.

→ Oval gear meter OGM<sup>PLUS</sup> mounted.

### 10.3.13 Configuration / Metering monitoring

If the metering monitoring function is enabled, the pump strokes are compared to the incoming pulses using a connected external metering monitor (e.g. oval gear meter). If a configurable tolerance threshold is breached, an alarm is triggered.

**NOTE** If an oval gear meter is connected as a metering monitoring unit and should be correspondingly evaluated, then the configuration/oval gear meter function must be enabled in addition to the configuration/metering monitoring function (see chapter [10.3.11](#)).

#### 10.3.13.1 Selecting

Fig. 10.33

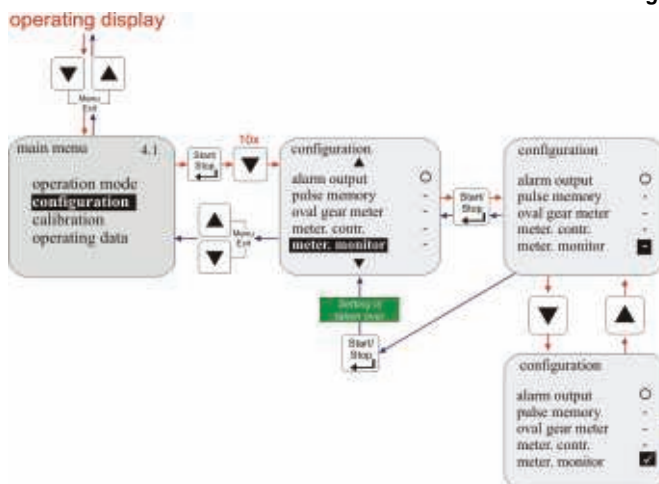

- metering monitoring is inactive. (Default setting)

✓ metering monitoring is active.

On activating metering monitoring, a submenu appears with the following menu items:

Menu item	Chapter
• Stop pump	<a href="#">10.3.13.2</a>
• Strokes	<a href="#">10.3.13.3</a>
• Deviation	<a href="#">10.3.13.4</a>
• Input	<a href="#">10.3.13.5</a>

### 10.3.13.2 Metering monitoring / Stop pump

The “stop pump” function is used to set whether or not the pump should be stopped if a “metering monitoring alarm” is triggered.

Fig. 10.34

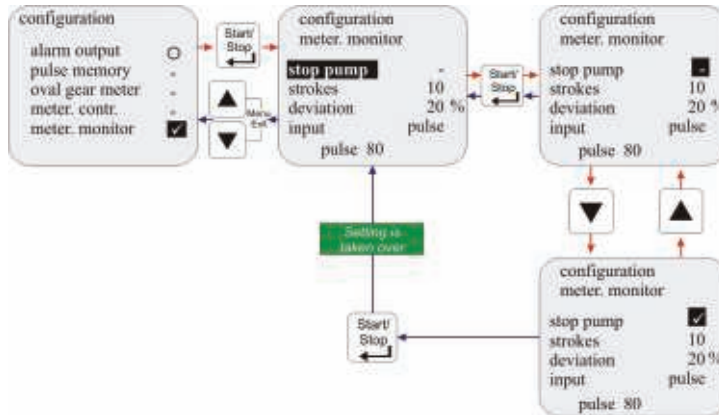

- Pump is not stopped when a “metering\_monitoring alarm” is triggered. (Default setting)
- ✓ Pump is stopped when a “metering\_monitoring alarm” is triggered.

### 10.3.13.3 Metering monitoring / Strokes

The “strokes” option indicates the stroke interval to be monitored.

Setting range: 0 – 100

Fig. 10.35

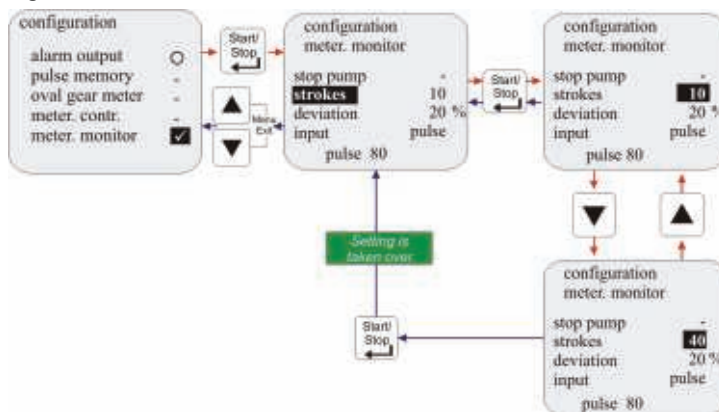

Default setting = 10

### 10.3.13.4 Metering monitoring / Deviation (only at E60<sup>PLUS</sup> & OGM or OGM<sup>PLUS</sup>)

A tolerance in % is set under “deviation”.

The actual incoming pulse rate recorded by the oval gear meter within the pump interval to be monitored (see chapter [10.3.13.3](#) configuration/strokes) is compared with the target pulse rate defined during calibration.

If this comparison results in a deviation that is greater than the % value configured under “deviation”, a “metering monitoring alarm” is triggered.

 **NOTE** This function can only be selected if a dongle box is connected and configuration/oval gear meter (see chapter [10.3.11](#)) has been activated.

Setting range: 0-100%

Fig. 10.36

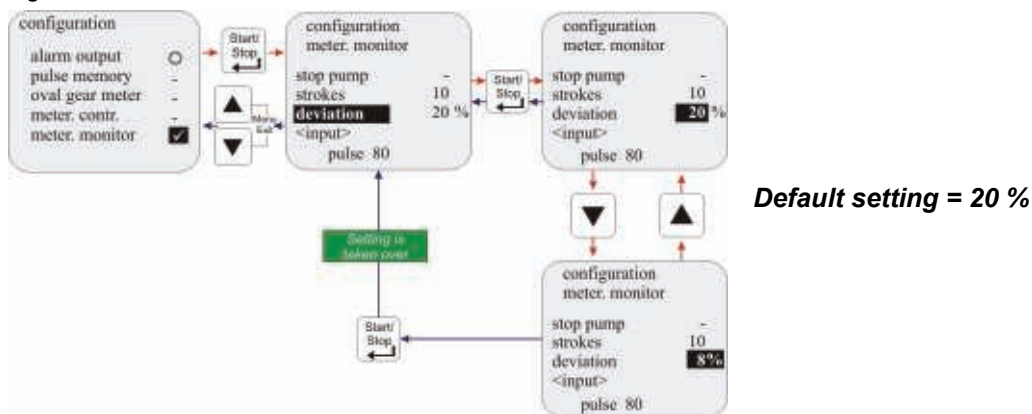

### 10.3.13.5 Metering monitoring / Input (only at E60 WITHOUT Dongle box)

The “Input” setting is used to determine which input (pulse input or metering lock) at plug II of the pump should be used to evaluate the incoming pulses from the metering monitoring unit.

The flow monitor connection depends on the selected input:

Input pulse: = plug II Pin 2+4

Input metering lock: = plug II Pin 3+4

See chapter [7.2.3.5](#).

 **NOTE** This function can only be selected if no dongle box is connected. In this case, the original function (e.g. pulse input) can no longer be used.

Fig. 10.37



### 10.3.13.6 Oval gear meter pulse display (only E60<sup>PLUS</sup>)

This display shows the number of pulses recorded during the last calibration process (running time during calibration = 1 min).

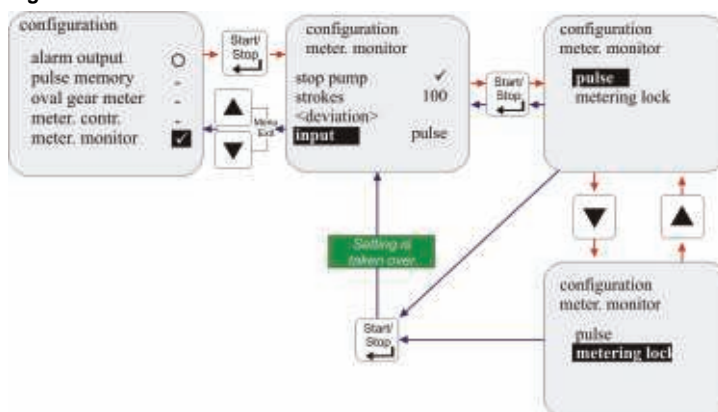
If the value shown is less than 60, metering monitoring using an oval gear meter is only possible to a limited extent.



Fig. 10.38

### 10.3.14 Configuration / MicroFlow<sup>PLUS</sup>

 <p><b>NOTE</b></p>	<p>If the "MicroFlow<sup>PLUS</sup>" metering monitoring unit (product no. 248611) is connected to plug II of the pump and the Plug &amp; Play function is activated through the temporary removal of the supply voltage or the pump being switched off and back on again, the configuration/meter monitoring menu item is automatically replaced by the configuration/MicroFlow menu item.</p> <p>When installing/commissioning the MicroFlow<sup>PLUS</sup> metering monitoring system, please consult the operating manual, product no. 417101314.</p>
--	---

This function makes it possible to use a metering monitoring system with which a metering pulse is emitted and evaluated on every pump stroke.

#### 10.3.14.1 Selecting

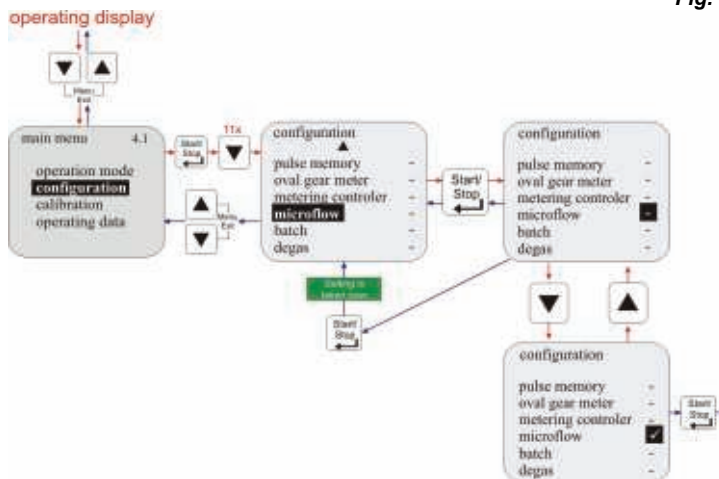

Fig. 10.39

- MicroFlow<sup>PLUS</sup> is inactive. (Default setting)
- ✓ MicroFlow<sup>PLUS</sup> is active.

On activating MicroFlow<sup>PLUS</sup>, a submenu appears with the following menu items:

Menu item	Chapter
• Stop pump	<a href="#">10.3.14.2</a>
• Strokes	<a href="#">10.3.14.3</a>
• Deviation	<a href="#">10.3.14.4</a>
• Metering break	<a href="#">10.3.14.5</a>
• Metering delay	<a href="#">10.3.14.6</a>
• Calibration	<a href="#">10.3.14.7</a>

### 10.3.14.2 MicroFlow<sup>PLUS</sup> / Stop pump

The "stop pump" function is used to set whether or not the pump stops if a "metering monitoring alarm" is triggered.

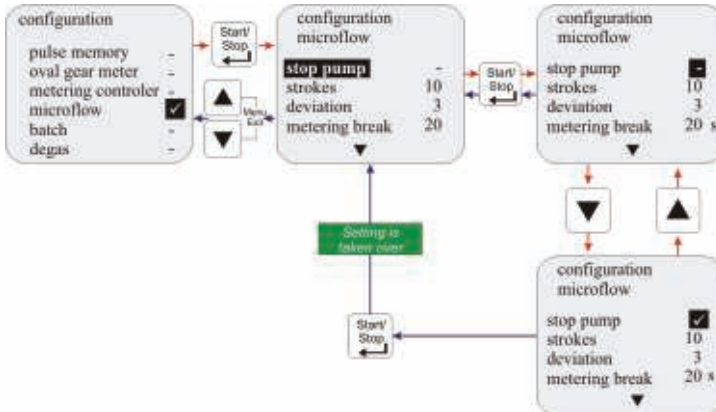

Fig. 10.40

- Pump is not stopped in the event of an „Alarm metering monitor function“ (Default setting)
- ✓ Pump is stopped in the event of an „Alarm metering monitor function“

### 10.3.14.3 MicroFlow<sup>PLUS</sup> / Strokes

The "Strokes" option is used to specify the interval of strokes to be monitored.

Setting range: 0-100

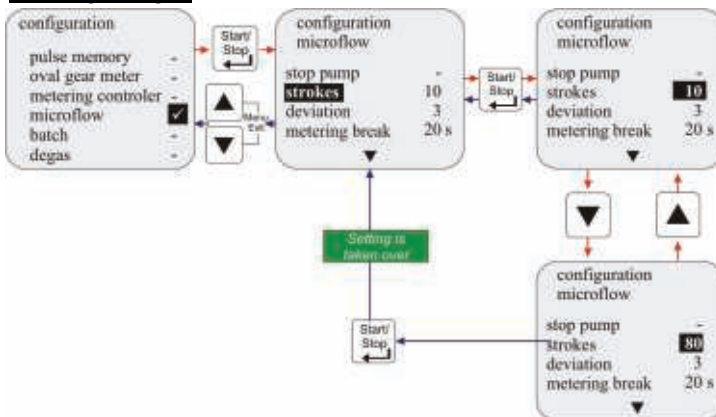

Fig. 10.41

Default setting = 10 strokes

### 10.3.14.4 MicroFlow<sup>PLUS</sup> / Deviation

The "Deviation" option is used to specify the number of undetected strokes permitted during the stroke interval to be monitored (see chapter 10.3.14.3 "Strokes") before the metering monitoring function issues an alarm.

Example: Strokes = 10, deviation = 3

This example accepts three undetected strokes in an interval of 10 strokes. An alarm is issued if four strokes are undetected.

Setting range: 0-100

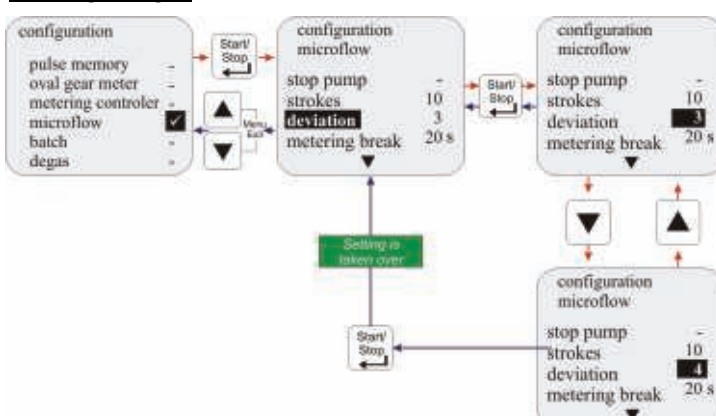

Fig. 10.42

Default setting = 3



### 10.3.14.5 MicroFlow<sup>PLUS</sup> / Metering break

When handling media with a tendency to emit gas, gas bubbles form in the system after extended downtimes, resulting in corrupted volume values of the quantity to be metered and subsequently to the non-detection of the metering strokes by the MicroFlow<sup>PLUS</sup> and the issuance of an alarm.

“Metering break” is used to set the period without metering after which the monitoring system is deactivated for a specific time (see [10.3.14.6 MicroFlow<sup>PLUS</sup> / Metering delay](#)) to prevent the undesired activation of the monitoring system.

Setting range: 2 - 3600s

Fig. 10.43

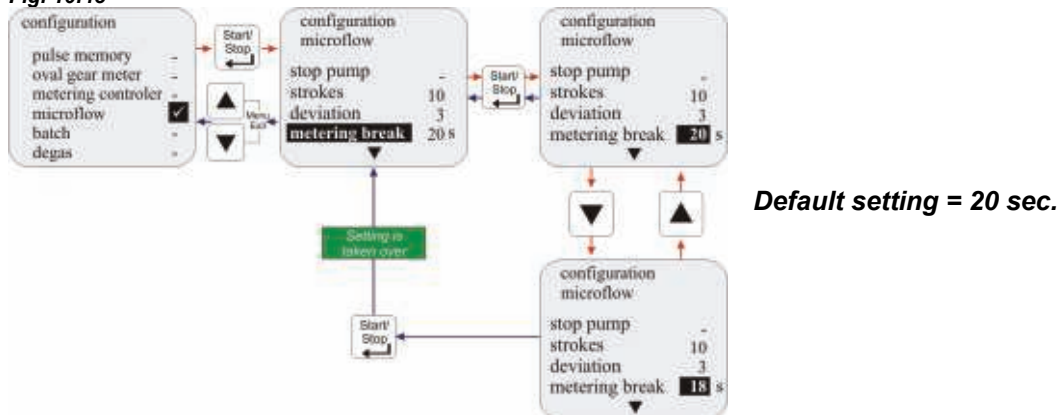

### 10.3.14.6 MicroFlow<sup>PLUS</sup> / Metering delay

Use the "Metering delay" option to specify the time during which the metering monitoring function is disabled when handling outgassing media to allow time for degassing the system. Once the metering pause time has expired, the "Metering delay" is activated as soon as the next metering is initiated (see chapter [10.3.14.5](#)).

Example: Metering pause = 20 s, metering delay = 10 s

This example has a metering pause of 20 seconds during which metering is stopped. The metering delay of 10 seconds is initiated with the next metering request during which the metering monitoring of the MicroFlow<sup>PLUS</sup> is interrupted. Any gas bubbles can be removed from the system without triggering an alarm during this time.

Setting range: 2 - 3600s

Fig. 10.44

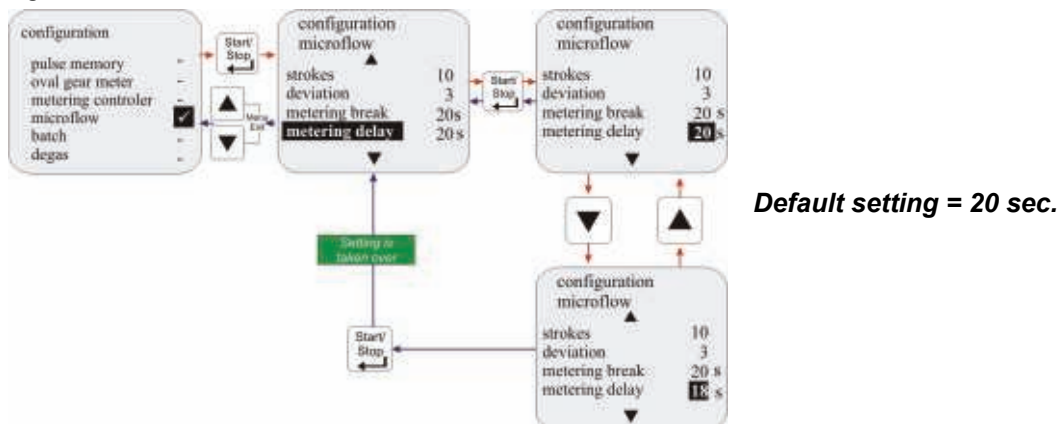

### 10.3.14.7 MicroFlow<sup>PLUS</sup> / Calibration

Use the "Calibration" option to newly calibrate the transducer during initial installation or when changing the product.

The pump must be running and the metering medium must flow through the transducers without any bubbles before starting the calibration process.

On activating the "calibration" function, the values for min. conductivity (electrical connection between the sensor pegs in the measuring sensor disrupted) und max. conductivity (electrical connection) are determined.

These values are then used to calculate and display a difference.

To monitor the system well, the difference should be greater than 3..4.

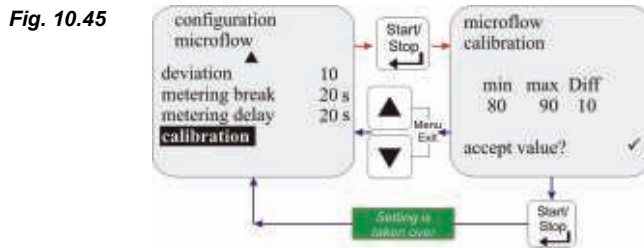

Fig. 10.45

### 10.3.15 Configuration / Batch

**NOTE** The pump must be calibrated before using batch metering (see chapter 10.4).

When activating batch mode with a signal to the metering lock/pulse input (plug II), a previously defined quantity is metered with 100 % stroke frequency.

The batch metering can be interrupted by deactivating the release (metering lock) or switching off the pump.

#### 10.3.15.1 Selecting

Fig. 10.46

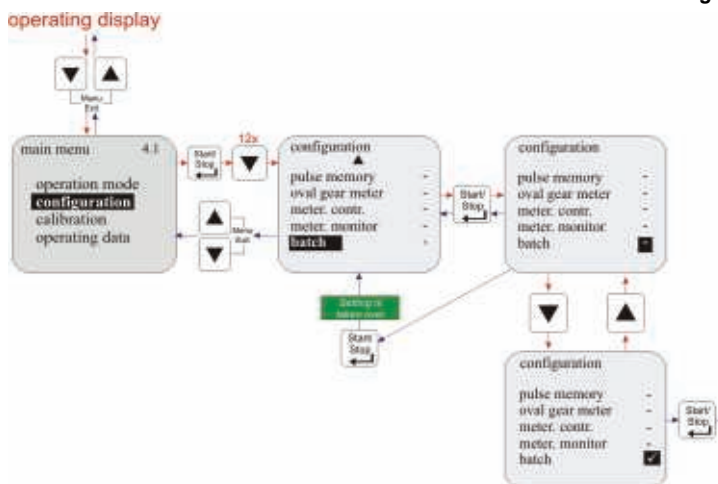

- Batch is inactive  
(Default setting)

✓ Batch is active

If batch metering is active, the following items appear in the submenu:

Menu item	Chapter
• Quantity	<a href="#">10.3.15.2</a>
• Input	<a href="#">10.3.15.3</a>

#### 10.3.15.2 Batch / Quantity

"Quantity" is used to establish the desired metering quantity (in µl, ml, l or G) per batch metering process. Setting range: 0 – 99999

Fig. 10.47

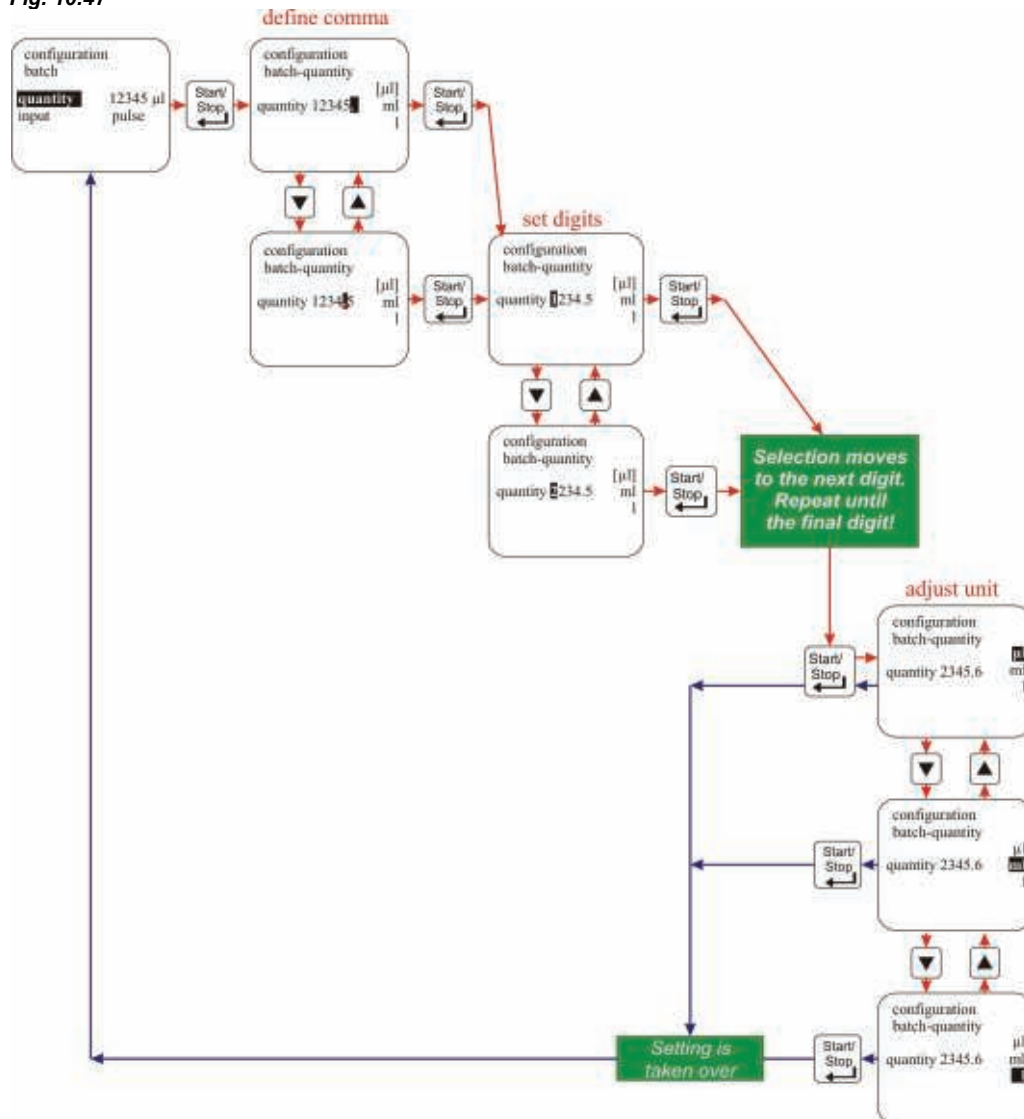

### 10.3.15.3 Batch / Input (only at E60 WITHOUT Dongle box)

The "Input" setting is used to determine which input (pulse input or metering lock) at plug II of the pump should be used to evaluate the start pulse for the batch metering.

The start pulse cable connection depends on the selected input:

Input pulse = plug II Pin 2+4

Input metering lock = plug II Pin 3+4

see chapter [7.2.3.4](#) and [8.2.2.1](#).



**NOTE**

In this case, the original function (e.g. pulse) can no longer be used.  
When using a dongle box, a separate input is available.

Fig. 10.48

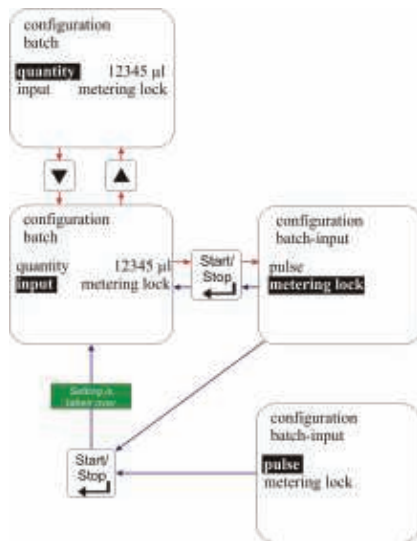

Default setting = Metering lock

### 10.3.15.4 Display in the operating display

Fig. 10.49



Pos	Description
1	Operation mode
2	Quantity remaining to be metered
3	Strokes remaining to be executed

### 10.3.16 Configuration Degas<sup>PLUS</sup>

On activating the “Degas<sup>PLUS</sup>” function and connecting an appropriate degassing valve, this function enables the metering system to be degassed for a controlled time period. When installing/commissioning the degassing valve, please consult the appropriate operating manual, product no. 417101377.

#### 10.3.16.1 Selecting

Fig. 10.50

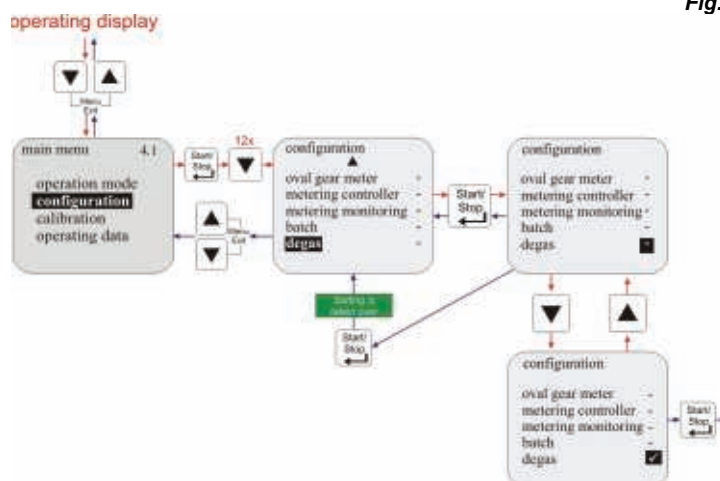

- “Degas<sup>PLUS</sup>” is inactive (Default setting)
- ✓ “Degas<sup>PLUS</sup>” is active

If degassing control is active, the following items appear in the submenu:

Menu item	Chapter
• Degas strokes	<a href="#">10.3.16.2</a>
• Degas break	<a href="#">10.3.16.3</a>

### 10.3.16.2 Degas / Degas strokes

The number of strokes that should be processed during a degassing interval is recoded under “degas strokes”.

Setting range: 1-100

Fig. 10.51

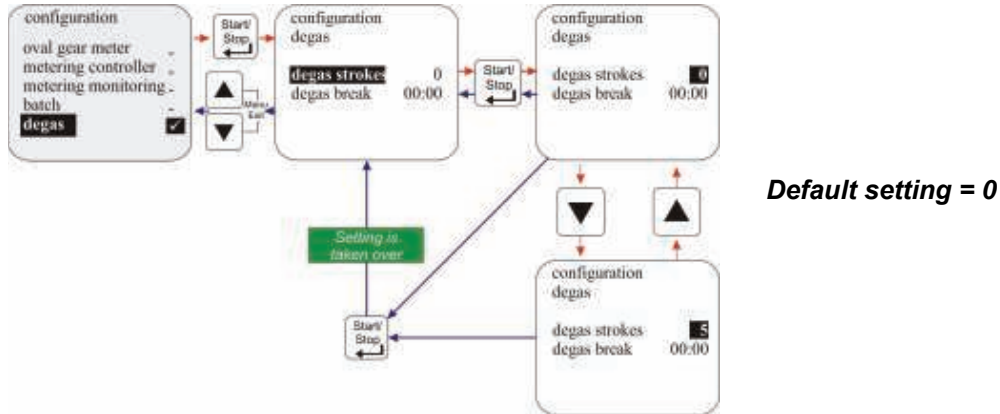

### 10.3.16.3 Degas / Degas break

The time between two degassing intervals is set under “degas break”.

If a metering request is submitted during this period, this is processed and the Degas<sup>PLUS</sup> break time is reset and restarted.

Setting range:

hours	00 - 23
minutes	00 - 59
total	00.01 - 23.59h

Fig. 10.52

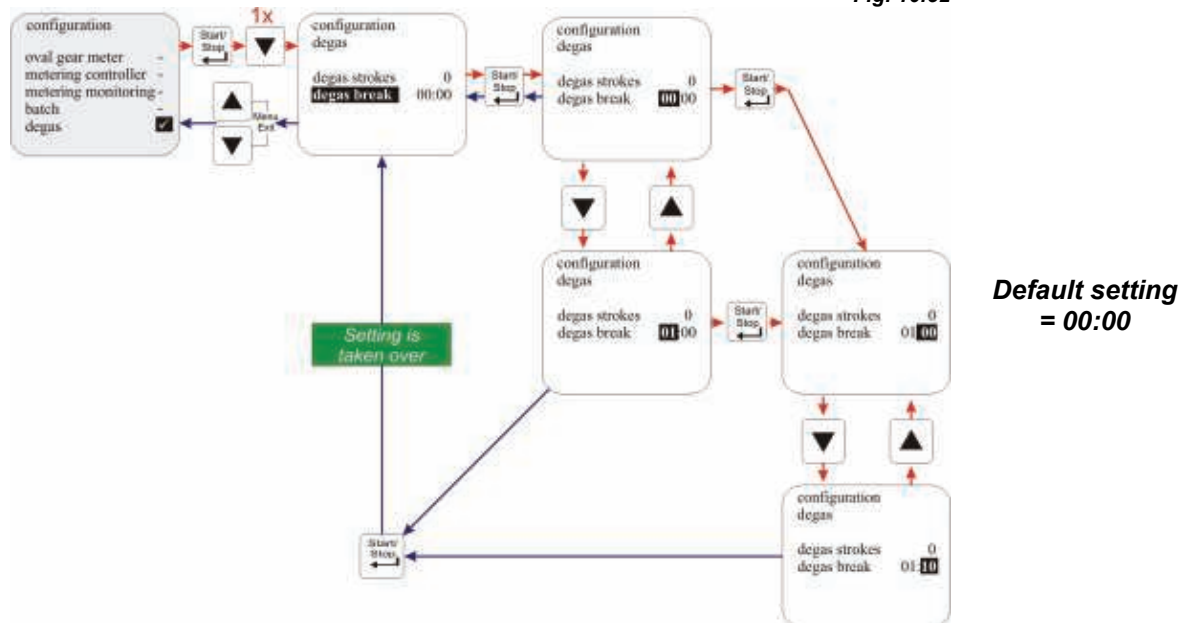

## 10.4 Calibration

### 10.4.1 Overview

The procedure and display during the calibration process differ depending on whether or not an oval gear meter is connected.

Fig. 10.53

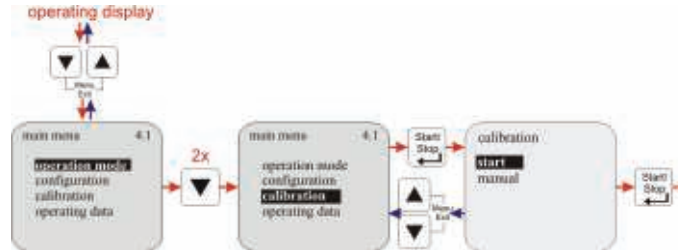

#### Calibration pump:

- see chapter [10.4.2](#)

#### Calibration pump with oval gear meter:

- see chapter [10.4.3](#)

### 10.4.2 Calibration pump

#### 10.4.2.1 Preparation

Fig. 10.54

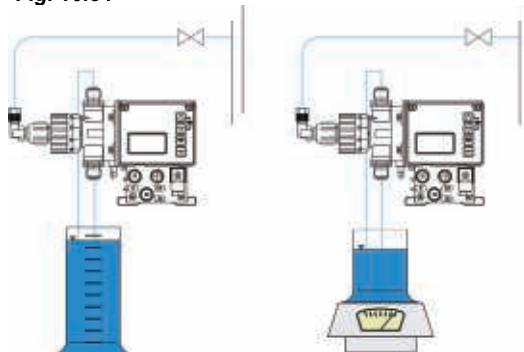

- ✘ Connect the pump ready for operation on the pressure side (see chapter [7](#) "Installing the device").
- ✘ Fill a suitable measuring cylinder and insert the suction line or suction and return line.



#### NOTE

The volume of the measuring cylinder should be 1/50 of the metering pump rate in litres/h. During this process, the suction line must not change its position. The calibration of the metering pump is only valid for the currently set stroke length setting. After changing the stroke length, the calibration must be performed again.

### 10.4.2.2 Calibration / Start

Fig. 10.55

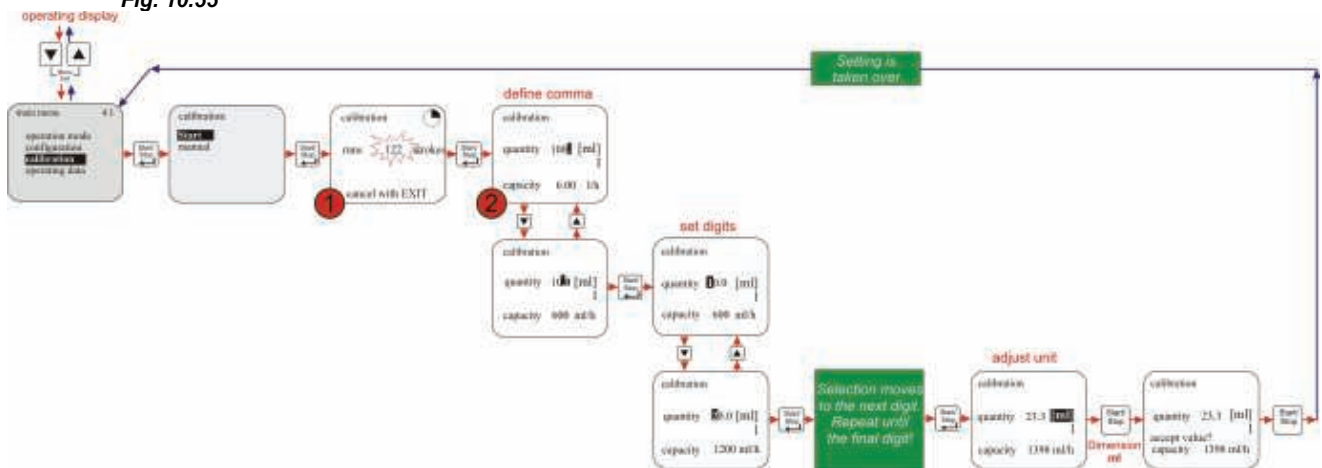

**to 1:** The pump runs 122 strokes (ca. 1 min).  
The strokes are counted down from 122 to 0.

**NOTE** By activating the 'Menu/Exit' function, the running calibration can be interrupted.

**to 2:** After the running process, the amount removed from the measuring cylinder (see chapter 10.4.2.1 "Preparation") must be read off.  
This quantity is then entered as the calibration value (in ml or l).

### 10.4.3 Calibration pump with oval gear meter (OGM<sup>PLUS</sup>)

If a dongle box and an oval gear meter are connected and the "oval gear meter" function (see chapter 10.3.11) is activated, the oval gear meter pulse rate recorded is automatically displayed at the end of the calibration process.

This is offset against the specified calibration value. A correlation thus occurs between the oval gear meter pulses and the metered quantity.

#### 10.4.3.1 Preparation

Fig. 10.56

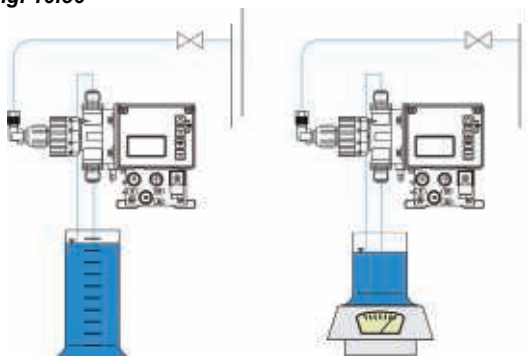

- ✘ Connect the pump ready for operation on the pressure side (see chapter 7 "Installing the device").
- ✘ Fill a suitable measuring cylinder and insert the suction line or suction and return line.

**NOTE** The volume of the measuring cylinder should be 1/50 of the metering pump rate in litres/h.  
During this process, the suction line must not change its position.  
The calibration of the metering pump is only valid for the currently set stroke length setting.  
After changing the stroke length, the calibration must be performed again.

### 10.4.3.2 Calibration / Start

Fig. 10.57

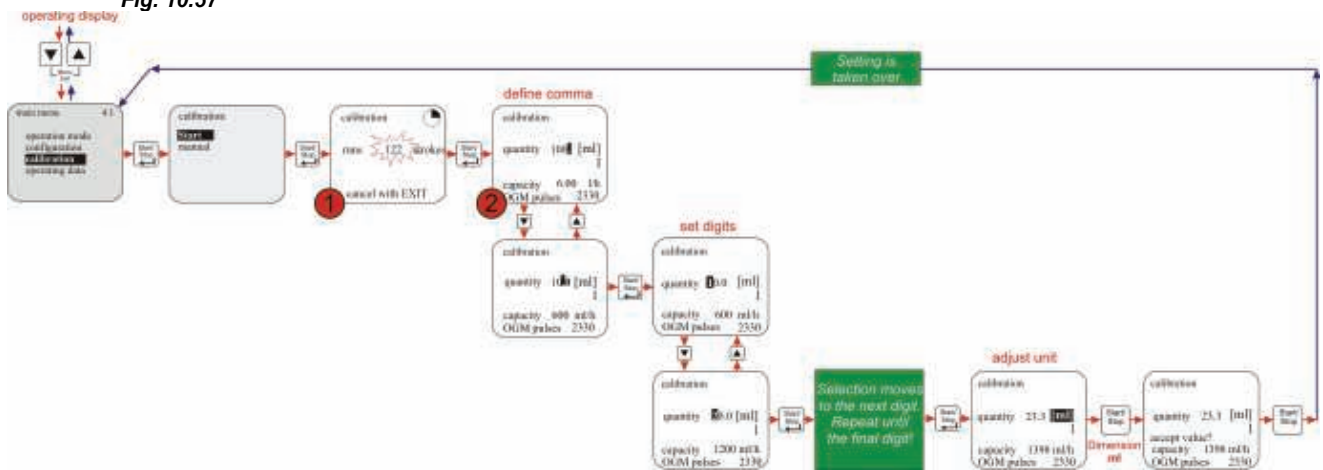

**to 1:** The pump runs 122 strokes (ca. 1 min).  
The strokes are counted down from 122 to 0.  
The oval gear meter pulses (OGM pulses) are counted upwards from 0.



**NOTE**

By activating the 'Menu/Exit' function, the running calibration can be interrupted.  
If the OGM pulses are **not** displayed, check all the connections to the pump!

**to 2:** After the running process, the amount removed from the measuring cylinder (see chapter 10.4.3.1 "Preparation") must be read off.  
This quantity is then entered as the calibration value (in ml or l).

Fig. 10.58



During the calibration process, the oval gear pulses determined appear on the display.



### 10.4.4 Calibration / Manual

If the calibration value to be entered is known, a “dry calibration” (immediate entry of the value without a previous calibration process) can be conducted.

However, this method is not very accurate as no consideration is given to the on-site conditions (back-pressure, viscosity, cable cross-chapters and lengths etc).

Fig. 10.59

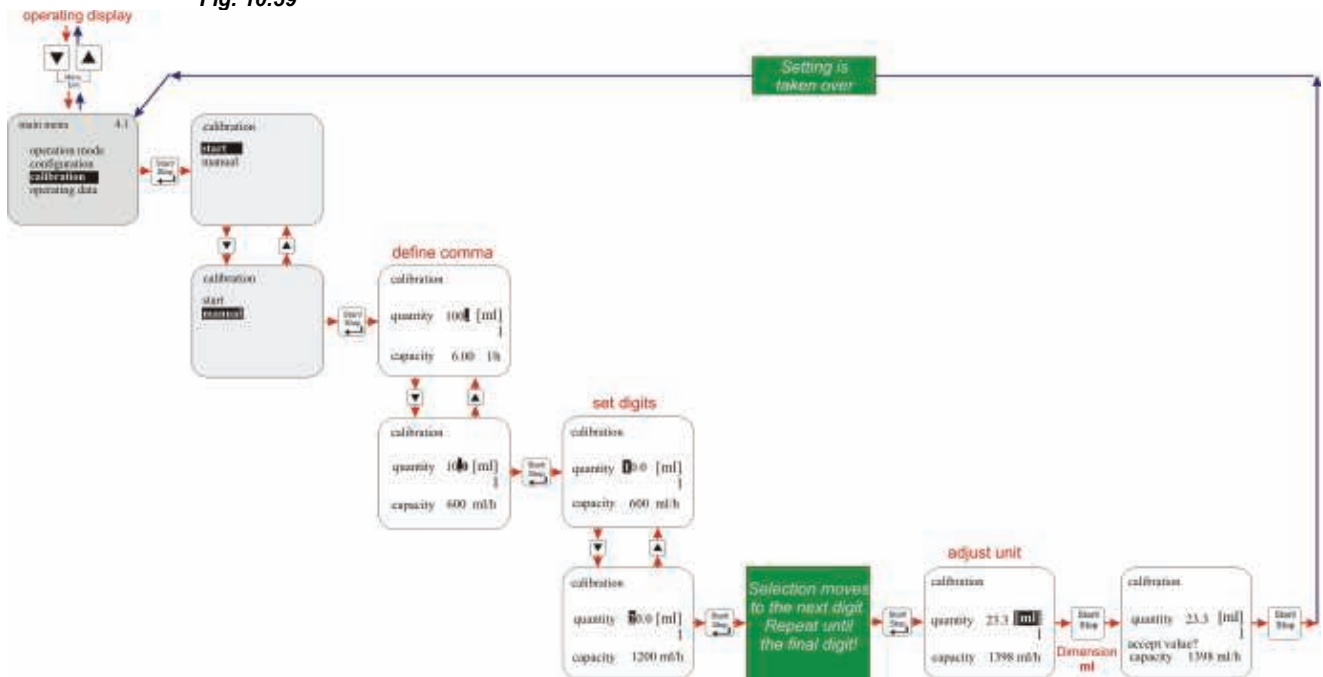

#### 10.4.4.1 Calibration data table

The pump capacity in l/h is allocated to the pump’s electronics on the basis of the calibration values entered in the table.

**Example:**

A specified value of 23.3 ml results in a pump capacity of 1.4 l/h.

**NOTE** These values relate to the metering medium of water at 20°C

	Pump	Pump capacity [l/h]	Pump calibration value [ml]
<b>EMP KKS</b>		0,2	3,33
		0,5	8,33
		0,9	15,0
		1,4	23,3

### 10.5 Operating data

The following operating data is recorded and displayed under this menu item:

- Operating hours
- Liter
- Amount of pulses

### 10.5.1 Overview

Fig. 10.60

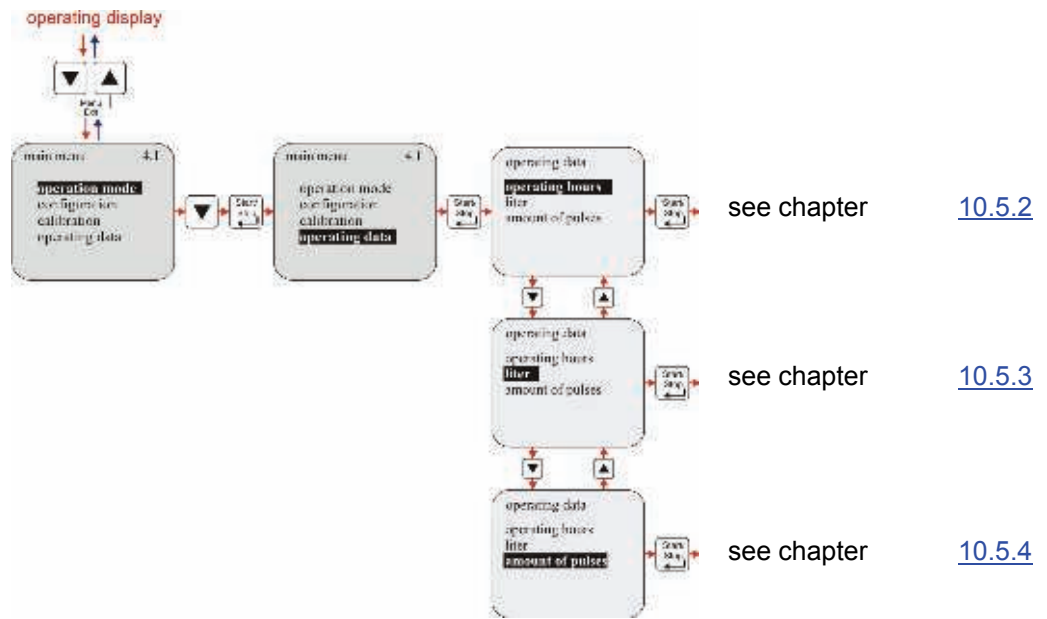

### 10.5.2 Operating data / Operating hours

The pump running time (number of strokes • 480 ms) since it was first commissioned or last reset is displayed.

#### 10.5.2.1 Selecting / Displaying / Deleting

Fig. 10.61

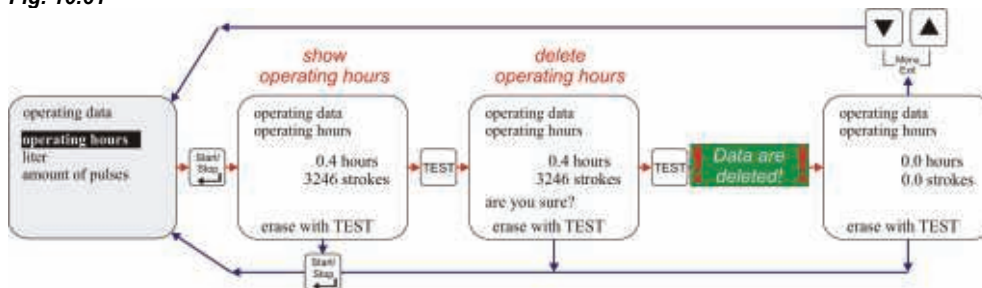

### 10.5.3 Operating data / Liter

The metered quantity in litres since the pump was first commissioned or last reset is displayed. On operating the pump without an oval gear meter, this value is calculated (ml/stroke • number of metered strokes). If an oval gear meter is connected, the measured quantity is displayed (determined from the number of oval gear meter pulses).

### 10.5.3.1 Selecting / Displaying / Deleting

Abb. 10.62

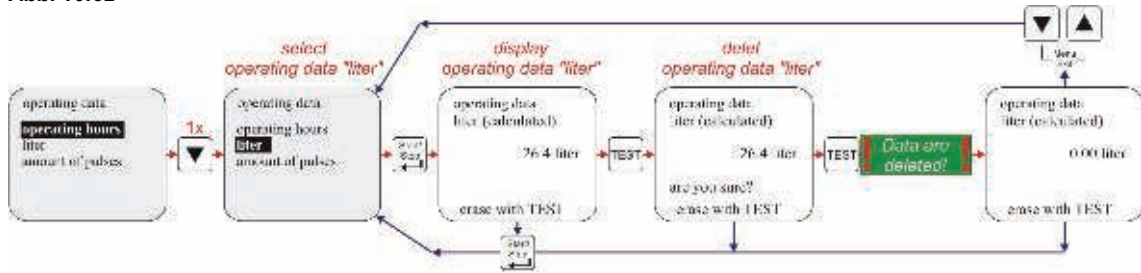

### 10.5.4 Operating data / Amount of pulses

The number of pulses received via the pump's pulse input (plus II pins 3+4, see chapter [7.2.3](#) "Plug II connection details") since it was first commissioned or last reset is displayed.

#### 10.5.4.1 Selecting / Displaying / Deleting

Fig. 10.63

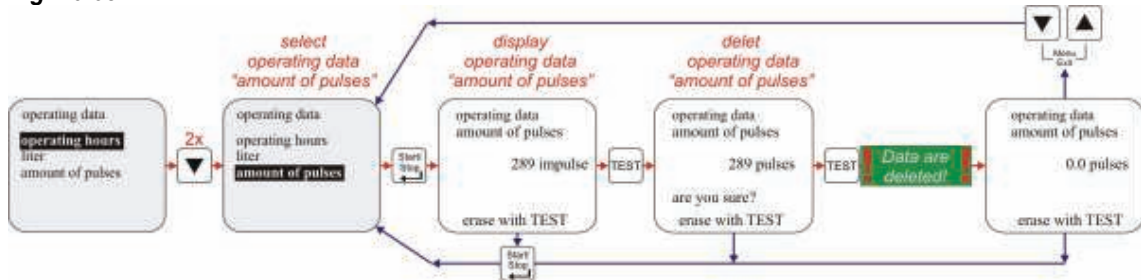

## 11 Maintenance

 **CAUTION** Metering pumps must only be maintained by technically competent and authorized persons.

 **NOTE** The maintenance interval is quarterly. Shorter intervals are recommended in the event of heavy loads (e.g. continuous use).

The following inspections are recommended:

- ✘ suction pipes and pressure pipes for leak-free connections
- ✘ suction valve and pressure valve (chapter [11.1](#), Fig. 11.1) for dirt and impermeability.
- ✘ discharge connection (chapter [5](#), Fig. 5.1) on the pump head (for diaphragm breakage).
- ✘ correct metering
- ✘ union nut (chapter [7.1.2](#), Fig. 7.6 and chapter [7.1.3](#), Fig. 7.7)
- ✘ metering head screws (chapter [11.2](#), Fig. 11.3, Pos. 2) (stable seat, 3 - 4 Nm)

 **NOTE** The life of the diaphragm depends on the: backpressure, operating temperature and metering medium. It is recommended to inspect the diaphragm more frequently in extreme operating conditions or if abrasive substances are metered.

### 11.1 Replacing the suction / return valve

Fig. 11.1

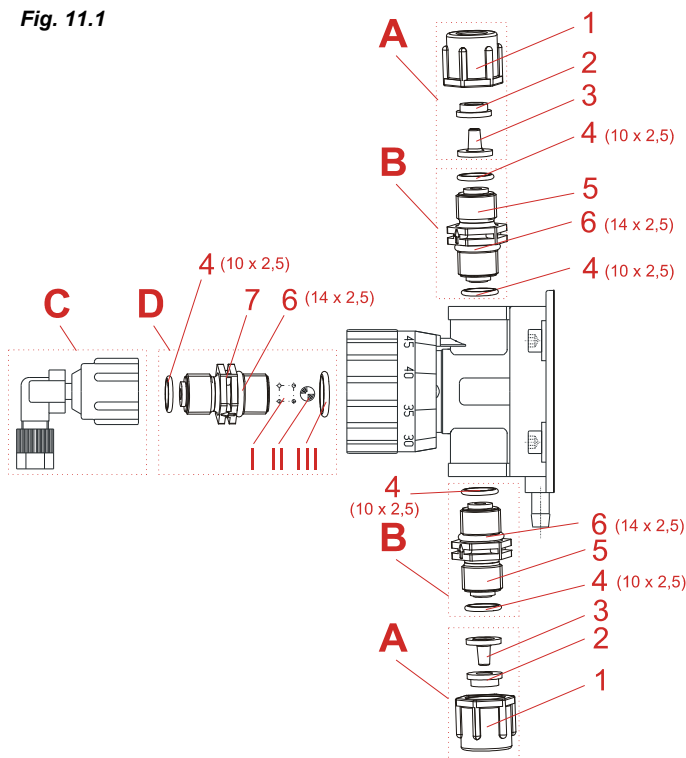

Pos.	Designation
<b>CONNECTION SET</b>	
<b>A</b>	1 Union nut
	2 Clamping piece
	3 Tapered part
<b>SUCTION-/RETURN VALVE</b>	
<b>B</b>	4 O-Ring, Ø 10 x 2,5
	5 Suction-/Return valve
	6 O-Ring, Ø 14 x 2,5
<b>ANGLE CONNECTION</b>	
<b>PRESSURE VALVE</b>	
<b>D</b>	4 O-Ring, Ø 10 x 2,5
	6 O-Ring, Ø 14 x 2,5
	7 Pressure valve (pressure line)
	I Valve spring
	II Valve-ball
	III O-Ring, Ø 12 x 1,5

- ✘ Disassemble the suction valve and pressure valve (pos. 5/7) with a crescent wrench (SW 22).

 **NOTE** Please observe, that the valve spring (pos. I), valve-ball (pos. II) and the o-ring (pos. III) are not lost and installed in the right direction at the pressure valve.

- ✘ Assemble all the O-rings.
- ✘ Screw in the suction valve and pressure valve in the correct position (torque of 2-3 Nm)

### 11.1.1 Inserting the metering valves in the correct positions

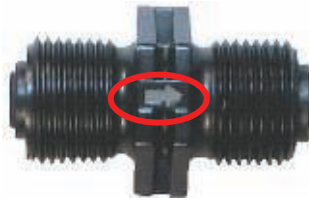

Fig. 11.2

On the suction valves and flow valves, the flow direction is marked with an engraved arrow.

When inserting it, always ensure that the valves are inserted according to the flow direction!

### 11.2 Replacing the diaphragm and pump head

Fig. 11.3

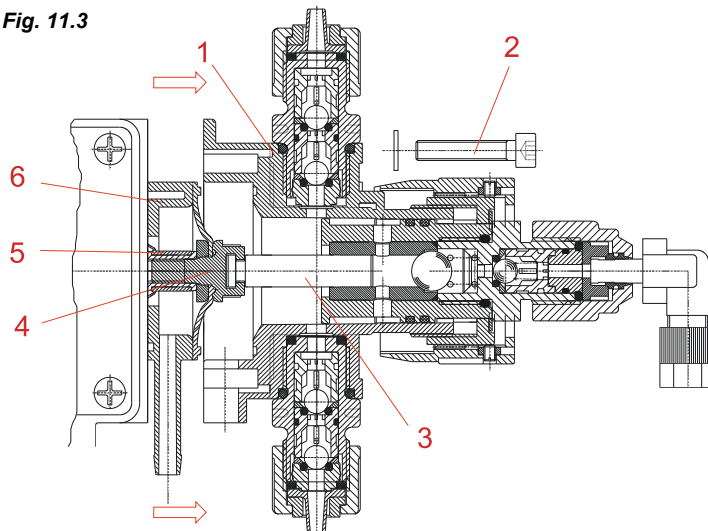

Pos.	Designation
1	Pump head
2	Metering head screw
3	Ceramics piston
4	Diaphragm unit
5	Bellows
6	Intermediate plate



**ATTENTION** Before opening pump head:  
✘ empty connecting lines,  
✘ rinse the pump head.

- ✘ Loosen the metering head screws (pos. 2).
- ✘ Take off the pump head (pos. 1) absolute straightly.



**ATTENTION** The ceramics cylinder can be destroyed when being set on edges!

- ✘ Take the ceramics piston (pos. 3) sideways out of the coupling of the diaphragm unit (pos. 4).
- ✘ Un-screw diaphragm unit (pos. 4).
- ✘ Remove intermediate plate (pos. 6).
- ✘ Exchange bellows (pos. 5).
- ✘ Do not overdraw the diaphragm unit (pos. 4) when tightening, screw **gently** until stop.
- ✘ The leakage connection of the intermediate plate (pos. 6) must be directed downwards.
- ✘ Re-insert the piston (pos. 3).
- ✘ Attach cylinder carefully on the pump head.
- ✘ Hand-screw pump head screws
- ✘ Screw-down cross-over pump head screws



**NOTE** Correct tightening torque: 3 to 4 Nm



**ATTENTION** Check metering-head bolt tightening torque after 24 hours.  
Screw down the pump head absolute straightly. Tighten the metering head evenly diagonally.

### 11.3 Replacement of ceramics cylinder unit with piston

Procedure as described in chapter [11.2](#).

Fig. 11.4

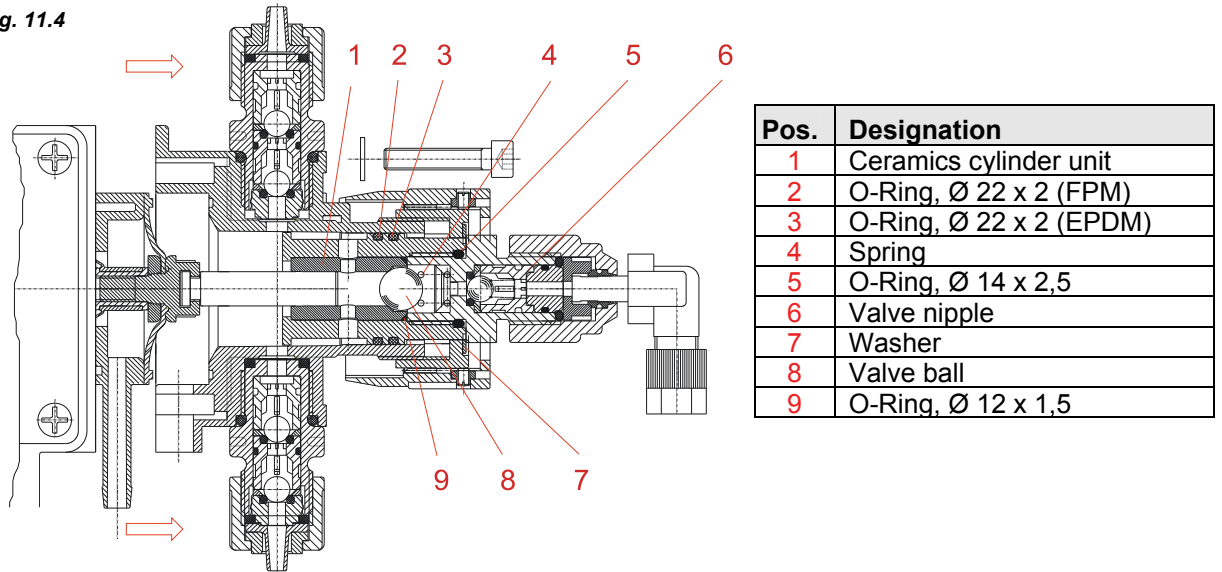

- ✘ Unscrew the valve nipple (pos. 6).
- ✘ Remove the washer (pos. 7), valve ball (pos. 8) and spring (pos. 4).
- ✘ Unscrew the ceramics cylinder unit (pos. 1) in direction of diaphragm seat.
- ✘ Insert a new unit. Replace the O-rings (pos. 2, 3, 5, 9)
- ✘ Re-install valve nipple (pos. 6), balls (pos. 8) etc.



**ATTENTION** The ceramic cylinder may only be exchanged in connection with the ceramic piston.

## 11.4 Description of the stroke scale

Fig. 11.5

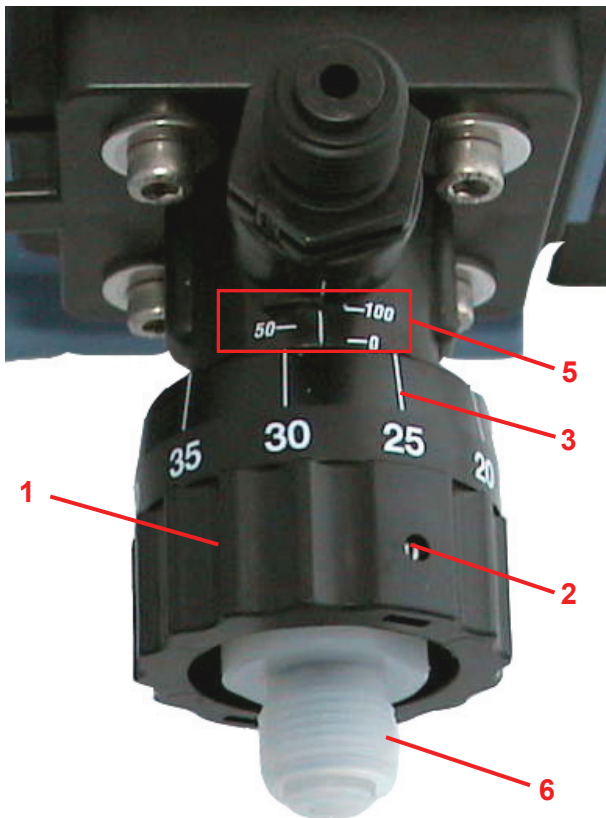

Pos.	Description
1	Stroke adjustment knob
2	Grub screws (2 x opposed)
3	Adjustment knob markings pict. 32 = 0 point)
4	Receiver for the adjustment knob (teethed)
5	Nonius scale
6	Metering connector

Fig. 11.6

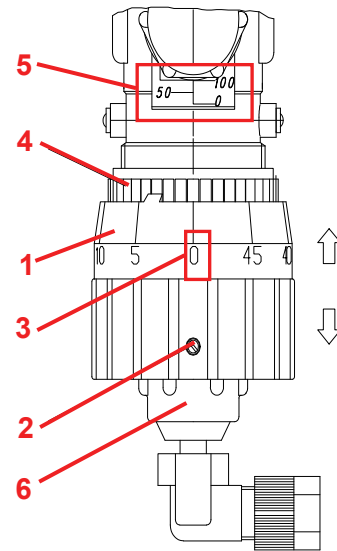

From factory-side the metering pump is set to nominal pressure, in accordance with the metering curves. If the stroke adjustment was changed by the removal of the position button, the basic position can be determined as follows:

- ✘ Switch-on metering pump.
- ✘ Loosen the 2 opposed grub screws (pos. 2).
- ✘ Now the stroke adjustment knob (pos. 1) can be removed from the subjacent tooth system (pos. 4).
- ✘ Turn the receiving part of the adjustment knob slowly to the left (pos 4) (counterclockwise), until no medium flows out of the metering connector (pos. 6).
- ✘ Slide up the adjustment knob (pos. 1) with the marking "0" (pos. 3), congruently on the marking line of the nonius scale (pos. 5). The adjustment knob has to be slid on the tooth system until the outer edge has reached the marking "-0" (pos. 5) of the nonius scale.
- ✘ Tighten again the grub screws (pos. 2).

The stroke setting has now been adjusted according to the special provisions.







**NOTE** To determine the metering capacity the pump ought to be engaged.





## 12 Operating faults

### 12.1 Metering warning messages (display)

If external signals are no longer being processed and the output signals (empty, fault) are switched off, the following error messages can be shown on the display of the metering pump:

Display	Meaning	Effect	Cause	Remedy
<b>Fig. 12.1</b> 	reserve report (flashing)	pump continues running	low-level advance warning active	Refill the metering medium
<b>Fig. 12.2</b> 	empty report	pump is stopped	empty report active	Refill the metering medium
<b>Fig. 12.3</b> 	metering lock (only possible if this is configured)	pump is stopped	no external enable of the pump	Activate external enable or deactivate the metering lock in the configuration menu. (See chapter 10.3.7)
<b>Fig. 12.4</b> 	Indicator in operation mode 4..20 mA flashes standard signal monitoring responds	pump is stopped	standard signal is under 3mA or cable to standard signal connection is broken	check the standard signal or cable
<b>Fig. 12.5</b> --.-	standard signal is above 23.0 mA	pump runs in continuous operation	standard signal exceeds the display range	reduce the standard signal

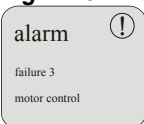
### 12.2 Alarm messages (display)

Display	Meaning	Effect	Cause	Remedy
<b>Fig. 12.6</b> 	Motor is running uncontrolled in continuous operation	over dosage	power electronic failure	replace PC-Board
<b>Fig. 12.7</b> 	Motor is not running despite of rotating dosing symbol.	no metering	backpressure too high	reduce pressure
			valve closed at pressure side	open valve
<b>Fig. 12.8</b> 	motor in continuous operation without request	continuous metering	Motor overheated/damaged power electronic failure	cool of the motor, or change replace PC-board
<b>Fig. 12.9</b> 	error in evaluating the metering monitoring or oval gear meter	pump meters too little or too much	optical sensor polluted PC-board fault Plug connection from gear to PC-Board interrupted	Send in pump control optical sensor connection
			tube fault	check the tubes
			diaphragm fault	check the diaphragm
			backpressure too high or too low	check the backpressure



### 12.2.1 Trouble shooting

Fault	Possible cause	Remedy
metering pump does not work, no display indicator	mains power cable damaged	change mains power cable
	incorrect voltage	check mains voltage
pump has no suction despite venting and max. strokes	deposits, adhesions or drying-out of the valves	rinse the metering head through the suction line, if necessary remove and clean or replace the valves
metering head is leaky, medium escapes from the diaphragm breakage outlet	metering head is loose	screw in the metering head fastening screw diagonally
	diaphragm is torn	replace the diaphragm
low-level indicator  appears on the display despite a full container	float of the suction pipe is jammed	unjam the float
	suction pipe plug or strapping plug is loose or not plugged in	tighten the plug, clean the contacts, check whether the strapping plug is plugged in
	suction pipe cable is faulty	replace the empty report device



**CAUTION**

Prior to repair and maintenance work and metering of dangerous media, always rinse the metering head, relieve the pressure pipe and wear protective clothing (protective goggles, gloves and apron).

Electronics repairs must only be performed by trained electricians, following the safety regulations of the professional association VB G 4 and ZH 1/11!



**CAUTION**

When opening the covers or removing parts, except when this is possible without tools, voltage-carrying parts may be exposed. Connection points may also be under live voltages.

Before calibration, maintenance, repairs or replacement of parts, the device must be disconnected from all voltage sources if it is necessary to open up the device.

### 13 Wearing parts and spare parts (standard version)

Fig. 13.1

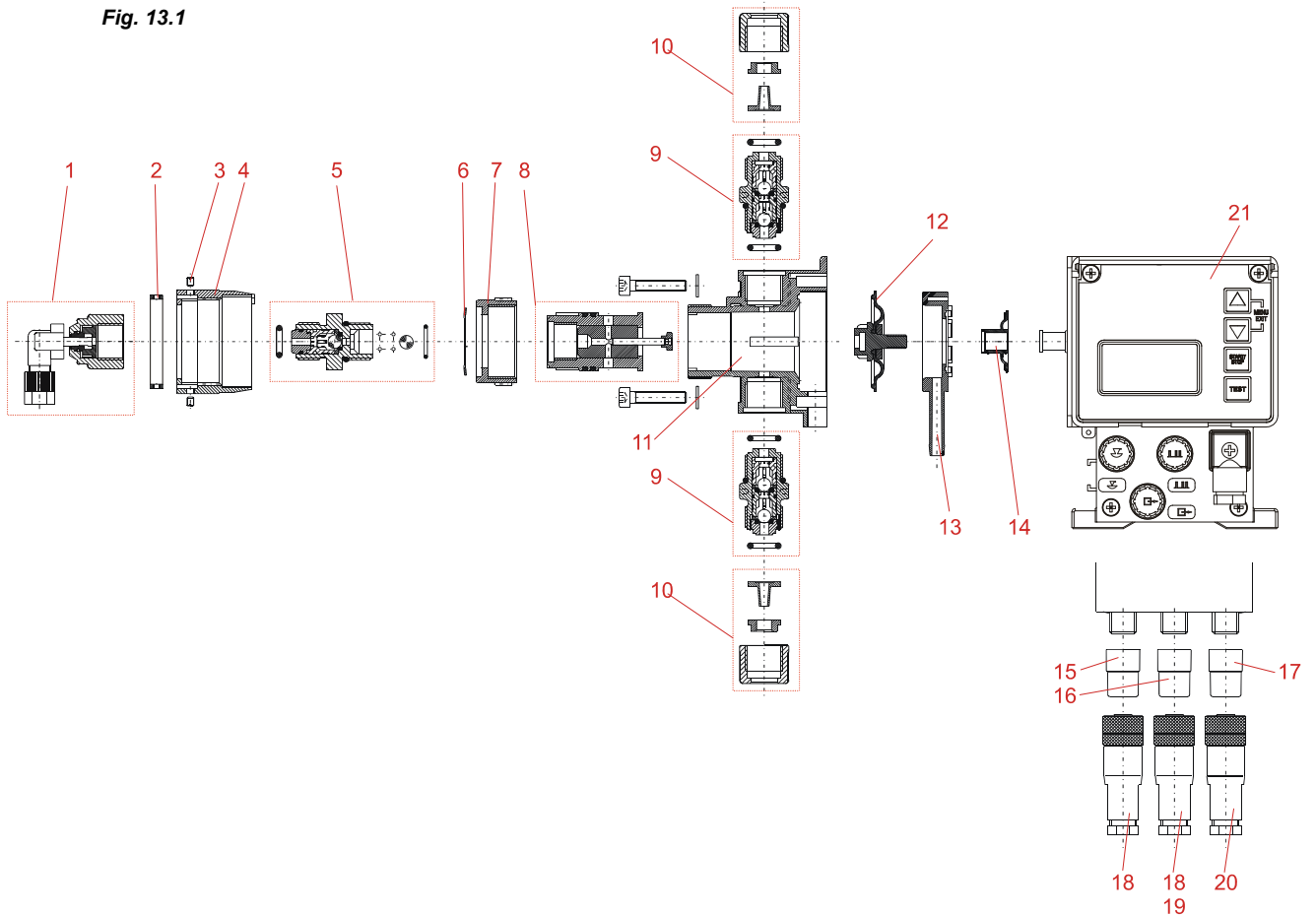

Pos.	Designation	article-no.
2	Square nut	413226005
3	Headless screw	413401178
4	Stroke adjustment button	34070193
6	Washer	34070186
7	Adjustment nut	34070185
9	Suction-/Return valve, SDVPVFPKE000 G3/8-G3/8-99	248405
10	Connection set 3/8" PVDF for hose 6/8, 6/10, 6/12 mm	247629
11	Pump head, PVDF	34070192
13	Intermediate plate	34070173
14	Protective Diaphragm (changing with pos. 12)	34760112
15	Bridge connector for empty signal-, pre-report	248186
16	Bridge connector pulse input	248187
17	Cover cap	34800117
18	Plug 4-pole (3-pole) empty signal-/pulse input	418463115
19	Plug 5-pole E 30/32 current-/pulse input	418463118
20	Plug 4-pole empty signal-/pulse output	418463117
21	Cover	34800120

Pos	Designation	type 00002	type 00005	type 00009	type 00014
1	Connection, angled, G 3/8"	247613	247620		
5	Pressure valve DRV PVFPKE004 G3/8 – G-3/8-99	247623	--		
	Pressure valve DRV PVFPKE008 G3/8 – G-3/8-99	--	247624		247630
8	Cylinder piston unit complete	247607	247609	247605	247604
12	Coupling/Diaphragm unit complete	247601	247608	247602	247601

## 14 Technical Specifications

### 14.1 Pump key

#### 1. Electrical version

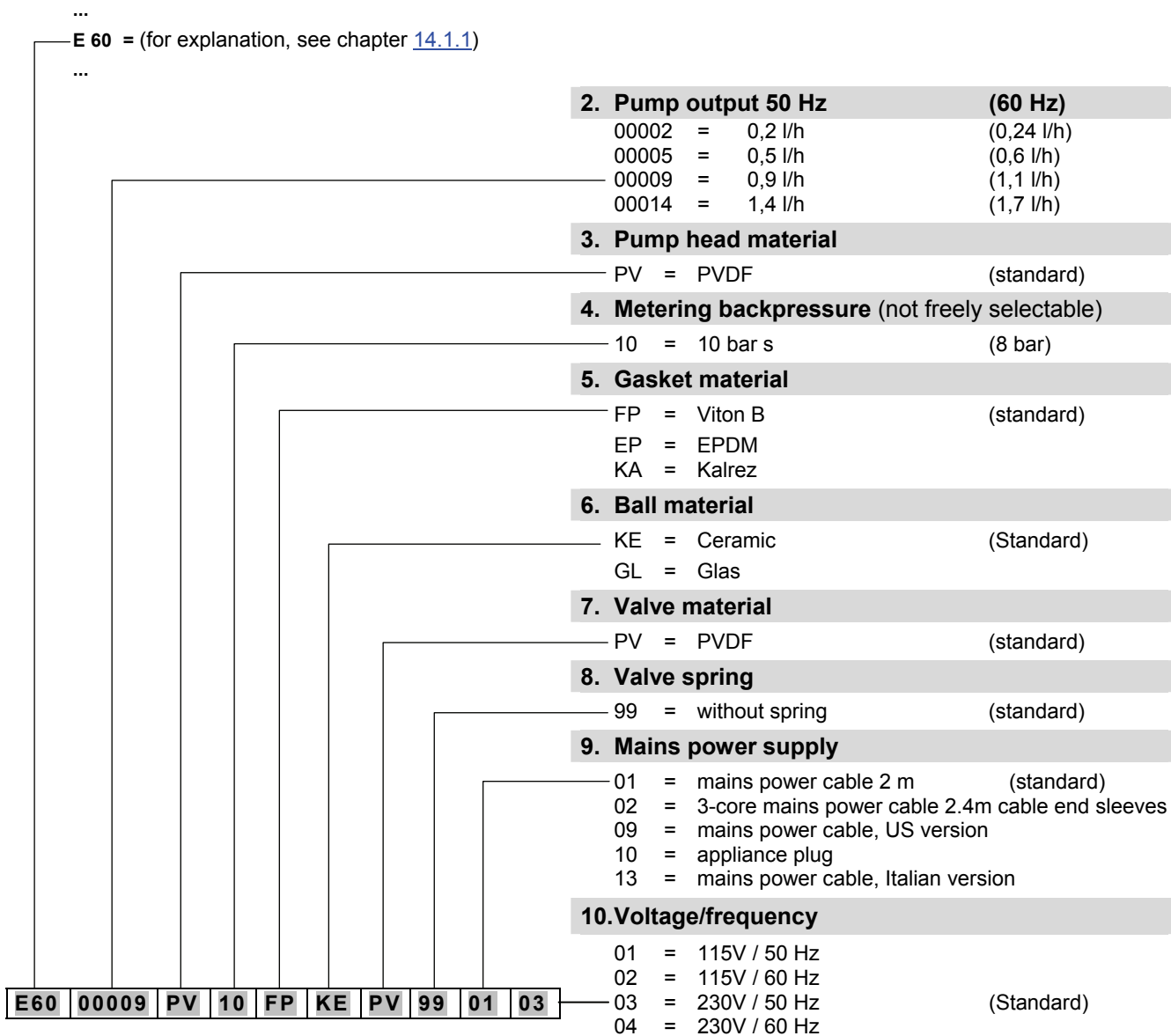

**Other specifications provided on request!**

**Pump key 2**

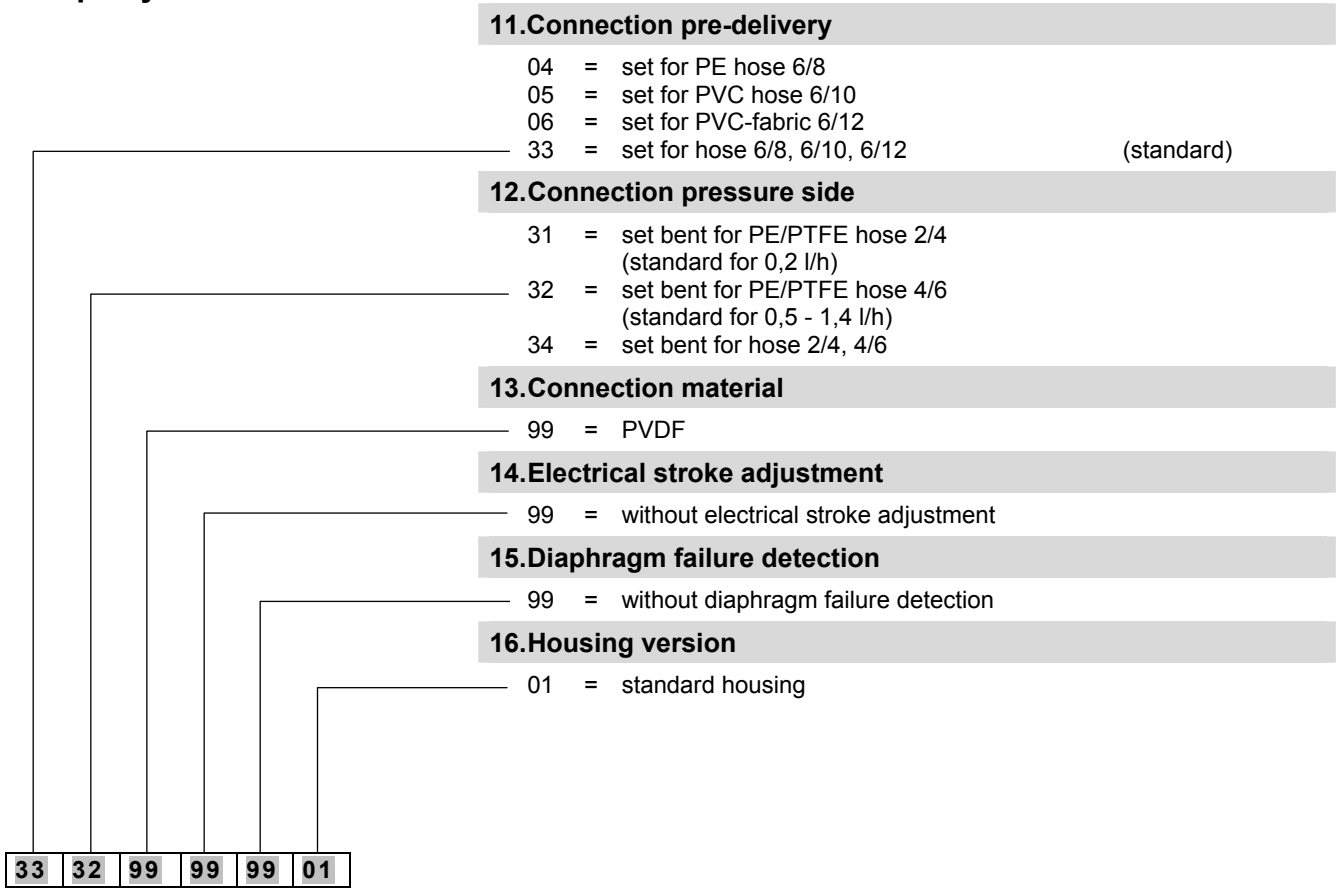

**Example of a complete pump code of a standard pump:**

E10	00009	PV	10	FP	KE	PV	99	01	03	-	33	32	99	99	99	01
(Pump code 1)											(Pump code 2)					

## 14.1.1 Pump key definition E60

### 1. Electrical version

#### E60

- On/Off switch for switching the pump
- mechanical stroke adjustment
- backlit graphical display, 4 control keys
- individual stroke control (each stroke is executed completely)
- metering control via stroke signal output (computed) or via external metering monitoring system
- collection of operating and consumption data (computed)
- calibration function

configurable operation modes:

#### Internal operation

Setting of metering quantity/metering frequency in:

- Strokes/min.
- Percentage
- Litres/hr (or gallons/hr)

#### External operation

- Pulse operation (control via pulses)
  - Pulse multiplication (1 incoming pulse = n metering strokes)
  - Pulse division (n incoming pulses = 1 metering stroke)
- Standard signal operation (control via external standard signal 0/4 - 20 mA or 20 - 0/4 mA)
- Batch operation (a preset quantity is metered after being triggered by external enable pulse)

#### Inputs:

- low-level monitoring of bundle holder (reserve and empty report)
- pulse
- standard signal
- enabling signal (metering lock)
- metering monitoring

#### Outputs:

- low-level monitoring of bundle holder / fault (reserve and empty report)
- Fault report
- stroke signal

#### E60<sup>PLUS</sup>

- *similar to E 60*, but with the addition of a **dongle box** for connecting of oval gear meter OGM<sup>PLUS</sup> (expansion unit for the capture of operating data)
- display of the currently measured metering quantity and automatic readjustment of pump output (only in conjunction with an external throughflow monitoring system, e.g. oval gear meter OGM<sup>PLUS</sup>)
- automatic calibration function via oval gear meter
- consumption data monitoring via oval gear meter

**14.2 Dimensions**

Fig. 14.1

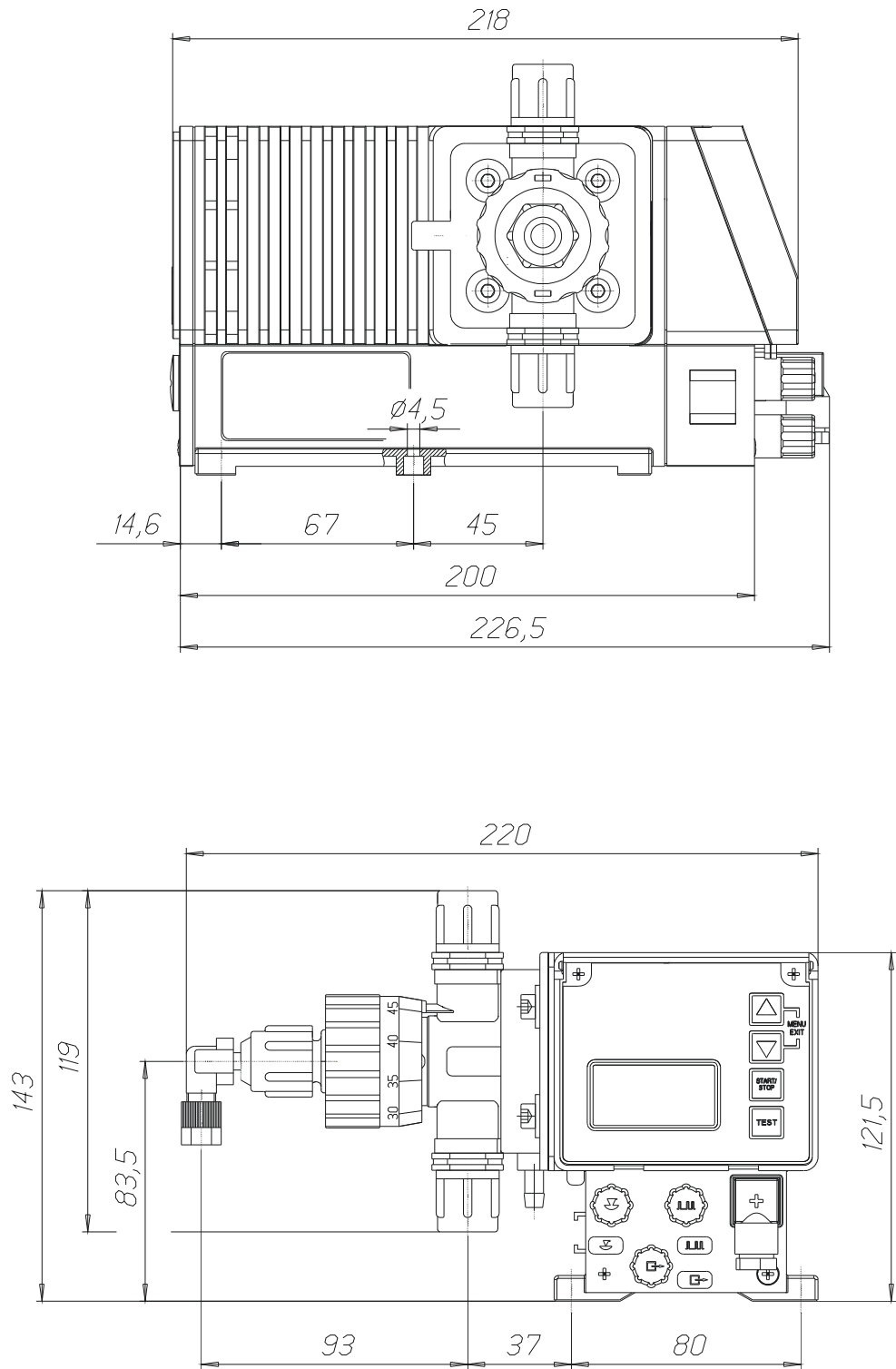

### 14.3 Technical specifications "Overview tables"

#### 14.3.1 General data

Description	Pump type			
	00002	00005	00009	00014
Supply voltage	230 V / 50/60 Hz *** ± 10 % (special voltages on request)			
max. power consumption I <sub>N</sub>	115V 50/60 Hz 230V 50/60 Hz	0,2 A / 0,21 A 0,09 A		
Motor power	115V 50/60 Hz 230V 50/60 Hz	18,7 / 19,8 W		
Fuse rating	315 mA			
Type of protection	IP 65			
Breaking capacity at circuit with 24 V Empty report output stroke signal output	24 V 3 A AC/DC 24 V 0,3 A DC			
Breaking capacity at circuit with 230 V Empty report output stroke signal output	230 V / 3 A AC/DC connection according to VDE is not permitted			

#### 14.3.2 General data - Standard pumps

Description	Pump type			
	00002	00005	00009	00014
Pump output [l/h]*	0,2	0,5	0,9	1,4
Max. metering backpressure [bar]	10			
Piston diameter [mm]	3	4,76	6,34	8
Number of strokes [1/min] at 50 Hz	122			
Metering quantity/stroke [cm <sup>3</sup> ] 50 Hz/60 Hz	0,027/0,032	0,068/0,082	0,12/0,44	0,19/0,23
Metering accuracy [see chapter 14.6]	< ± 3%			
Max. conveyable viscosity [mPas]	200			
Permitted ambient temperature	5-40°C			
Suction height [mWs] at 100 % stroke**	2			
Max. pre-pressure (suction side) [bar]	0,3			
Hose connectors Suction-/Returnline [ID mm]	6/8, 6/10, 6/12			
Hose connectors Pressure(metering)line [ID mm]	2/4	4/6		
Weight [kg]	2,4			

\* all data relate to water at 20 °C

\*\* Suction heights with clean, moistened valves at 100% metering stroke and max. stroke frequency

\*\*\* At a mains power frequency of 60 Hz, the delivery capacity increases by 20%, while the metering backpressure decreases by 20%.

### 14.3.3 In-/ and output circuit

#### 14.3.3.1 Connector I

Fig. 14.2

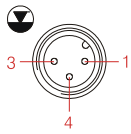

input	allocation	external circuit	declaration of value
empty report	1 + 4	voltage-free contact	
reserve	3 + 4	<b>Note: do not connect any external voltages!</b>	

#### 14.3.3.2 Connector II

Fig. 14.3

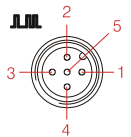

input	allocation	external circuit	declaration of value
pulse	2 + 4	voltage-free contact <b>Note: do not connect any external voltages!</b>	minimum power-on and power-off time 15ms
metering lock/ batch/ metering monitoring	3 + 4		
standard signal	4 + 5	external current <b>Note: Observe the polarity of the connected signal!</b>	0/4-20 mA, load approx. 50 ohms
output	allocation	external circuit	declaration of value
external power supply	1 + 4	voltage-free contact <b>Note: do not connect any external voltages!</b>	Power supply for ext. devices Outputs: 5VDC; max. 50mA

#### 14.3.3.3 Connector III

Fig. 14.4

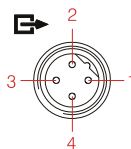

output	allocation	external circuit	declaration of value
stroke signal	3 + 4	external current <b>Note: Observe the polarity of the connected signal!</b>	max. external voltage 24 V DC, max 0,3 A when stationary: Contact open <b>at 50 Hz mains power:</b> <i>at 100 % run:</i> contact approx. 310 ms closed contact approx. 180 ms opened <i>at 50 % run:</i> contact approx. 310 ms closed contact approx. 660 ms opened <b>at 60 Hz mains power:</b> <i>at 100 % run:</i> contact approx. 260 ms closed contact approx. 150 ms opened <i>at 50 % run:</i> contact approx. 260 ms closed contact approx. 550 ms opened
empty/reserve/fault report	1 + 2	external current	max. external voltage 230 VAC/DC max. 3 A <b>with reserve report:</b> contact approx. 500 ms closed contact approx. 500 ms opened



## 14.4 Materials

Pump head:	PVDF
Metering piston/-cylinder:	Ceramic
Diaphragms:	PTFE-EPDM composite
Seals:	FPM (Viton B), optionally EPDM
Valves:	PVDF
Valve balls:	Ceramics
O-ring:	FPM, optionally EPDM
Valve springs:	Hastelloy C4/C22 PTFE coated
Housing:	thermoplastic polyester
Colour:	blue, RAL 5007

Special versions available on request.

## 14.5 Connector assignments

### 14.5.1 Connector assignments: Connector I (3-terminal)

Fig. 14.6 Connector for low-level advance warning or empty report

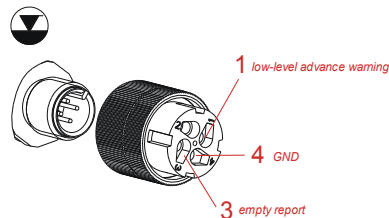

#### WARNING

In the event that the empty report is not used, contact 3/4 must always be bridged! The protective cap provided for this (see chapter 7.2.1) creates the bridge between the contacts and must be attached in this case.

See also chapter: [7.2.2](#)



#### NOTE

The empty and reserve report input can be inverted in the "Configuration / Low-level contact" menu. (see chapter [10.3.8](#))

### 14.5.2 Connector assignments: Connector II (5-terminal)

Fig. 14.7 Connector for pulse / standard signal input and metering lock

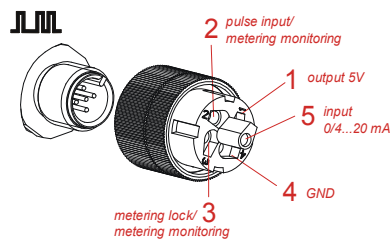

#### NOTE

The metering lock input is only active if it has been previously set in "Configuration / metering lock" menu. (see chapter [10.3.7](#))  
The batch function (see chapter [10.3.15](#)) and metering monitoring (see chapter [10.3.13](#)) must also be configured.

See also chapter [7.2.3](#)

### 14.5.3 Connector assignments: Connector III (4-terminal)

Fig. 14.8 Connector for empty report, fault and stroke signal output:

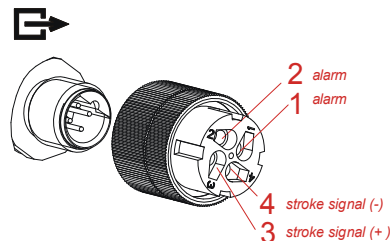

#### WARNING

At 115V/230 V, a simultaneous connection of contact 1/2 (alarm output) and 3/4 (stroke signal output) is generally not permitted.

See also chapter [7.2.4](#)

## 14.6 Metering rates

Repeatable metering accuracy is approx.  $\pm 3\%$  at minimum 30 % stroke length and otherwise constant conditions. In order to balance the clearance, the stroke length adjustment has to be based on the lower value towards the desired stroke length (= sense of rotation to the right).

Due to the characteristics of the pump, higher output can be produced until the operating temperature is reached.

Precise metering can be achieved provided the following items are adhered to:

- All metering-rate data is referred to measurements using water at 20° C, constant supply voltage and the metering pump at operating temperature.
- A pressure-maintenance valve (or metering valve) for generation of the most constant possible counter pressure of not less than 0.5 bar should be used in order to obtain high metering accuracy in case of metering with unobstructed discharge.
- If there is pre-pressure on the suction side, the pressure difference between the suction and the pressure sides must be at least 1 bar. The water column on the metering pump must be protected by an appropriate valve arrangement.



### NOTE

A pressure control valve or a metering valve is not an absolutely hermetically sealing shutoff device.



### WARNING

Metering stroke adjustment may only be performed with the pump running if the stroke adjusting screw is released.

## 14.7 Delivery capacity in relation to the back pressure

Setting accuracy + 15 % - 5 % of the nominal value; all data relate to water at 20 °C and comply with the notes in the operating instructions.



### NOTE

The tender specifications are shown at a pump frequency of 50 Hz.

Fig. 14.8

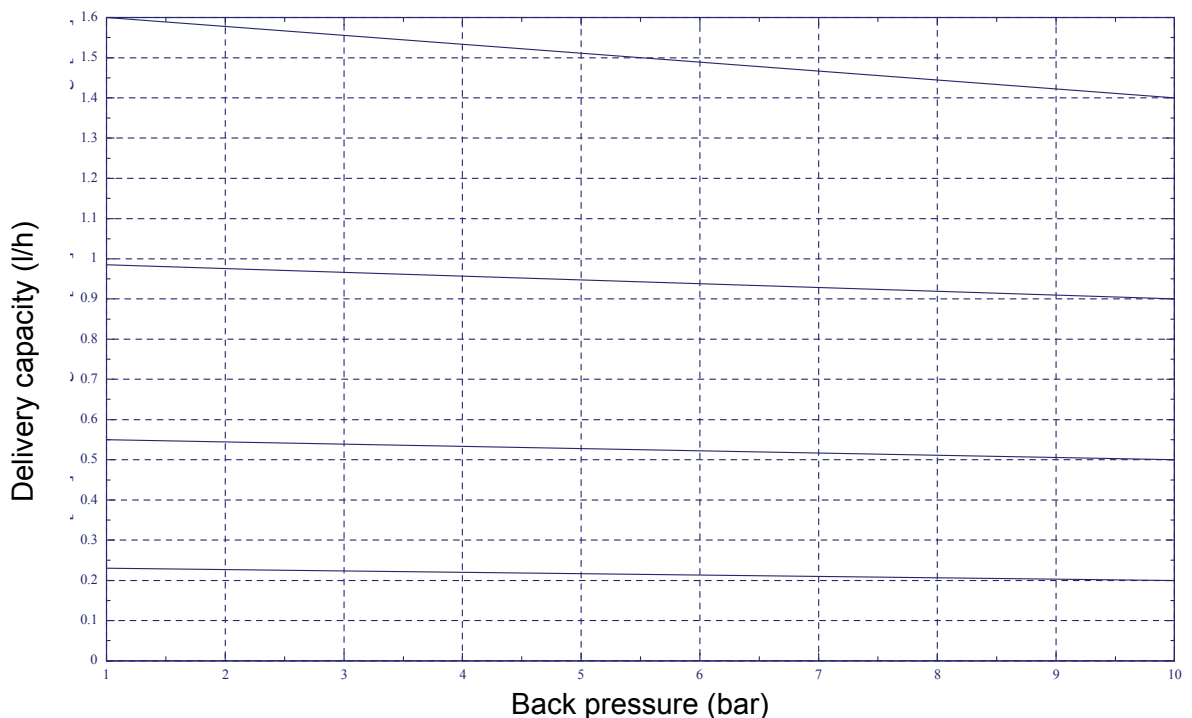

**14.7.1 Delivery capacity in relation to the stroke length**



Setting accuracy + 15 % - 5 % of the nominal value; all data relate to water at 20 °C and comply with the notes in the operating instructions.

 **NOTE** The tender specifications are shown at a pump frequency of 50 Hz.

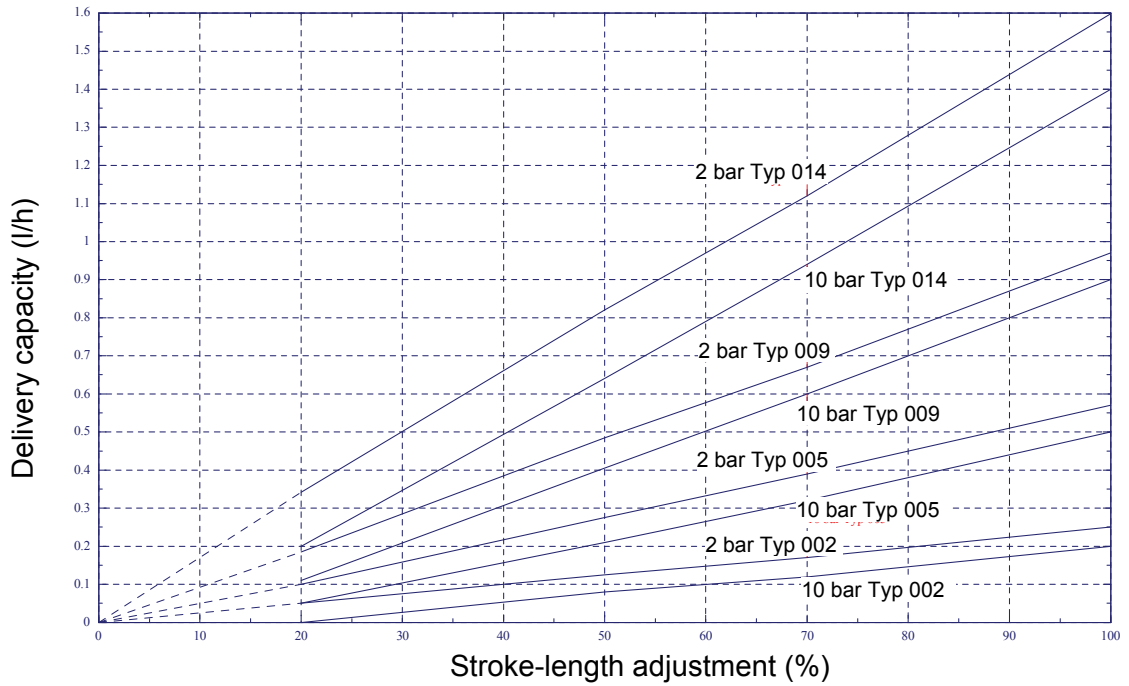
Fig. 14.9

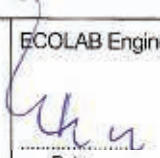

## 15 Declaration of Conformity

<b>ECOLAB</b>	EG-Konformitätserklärung Declaration of Conformity Déclaration de Conformité	(2006/42/EG, Anhang II A) (2006/42/EC, Annex II A) (2006/42/CE, Annexe II A)	<b>CE</b>	
	Dokument/Document/Document:	KON029335		
	Wir	We		Nous
	ECOLAB Engineering GmbH Postfach 11 64 D-83309 Siegsdorf			
Name des Herstellers, Anschritt	supplier's name, address	nom du fournisseur, adresse		
erklären in alleiniger Verant- wortung, dass das Produkt	declare under our sole responsibility that the product	déclarons sous notre seule responsabilité que le produit		
<b>ELADOS TYP EMP</b>				
Gültig ab / valid from / valable dès: 01.01.2010				
auf das sich diese Erklärung bezieht, mit der/den folgenden Norm(en) oder normativen Dokument(en) übereinstimmt:	to which this declaration relates is in conformity with the following standard(s) or other normative document(s):	auquel se réfère cette déclaration est conforme à la (aux) norme(s) ou autre(s) document(s) normatif(s)		
DIN EN 809	EN 60335-1+A11+A1+A12+A2 EN 6100-6-2 (2005-08) EN 6100-6-3+A11 (2004-07)			
Gemäß den Bestimmungen der Richtlinie	following the provisions of directive	conformément aux dispositions de directive		
2006/42/EG 2004/108/EG				
Bevollmächtigter für die Zusammenstellung der technischen Unterlagen: Authorised person for compiling the technical file: Personne autorisée pour constituer le dossier technique:		ECOLAB Engineering GmbH Postfach 1164 D-83309 Siegsdorf		
D-83313 Siegsdorf, 15.12.2009		ECOLAB Engineering GmbH  Rutz  I.V. Kamml		
Ort und Datum der Ausstellung Place and date of issue Lieu et date		Name/Unterschrift des Befugten name/signature of authorized person nom/signature du signataire autorisée		